

GUIDELINES for SNOWMOBILE TRAIL GROOMER OPERATOR TRAINING

*A Resource Guide for Trail Grooming
Managers and Equipment Operators*



Produced by



2005

GUIDELINES for SNOWMOBILE TRAIL GROOMER OPERATOR TRAINING

Project Manager:

Kim Raap – Trails Work Consulting

TrailsWork@aol.com

4015 S. Brady Court
Sioux Falls, SD 57103
(605) 371-9799

Request Copies from:

American Council of Snowmobile Associations (ACSA)

www.snowmobilers.org

271 Woodland Pass, Suite 216
East Lansing, MI 48823
(517) 351-4362



This document is disseminated under the sponsorship of the Department of Transportation in the interest of information exchange. The United States Government assumes no liability for the contents or use thereof. The contents of this manual do not constitute a standard, specification, or regulation.



U.S. Department of Transportation
Federal Highway Administration

ACKNOWLEDGEMENTS

This resource guide has been produced with financial assistance from the Recreational Trails Program administered by the U.S. Federal Highway Administration (FHWA) with additional funding from the International Association of Snowmobile Administrators (IASA).

The International Association of Snowmobile Administrators and the American Council of Snowmobile Associations (ACSA), as well as the individuals within those organizations and others are recognized for their input, project coordination, support, and suggestions in the development of this resource guide. A special mention is given to Kim Raap and Trails Work Consulting for project management, writing, and photographs.

A special thank you to the snowmobile trails programs in the states of California, Colorado, Michigan, New Hampshire, New York, South Dakota, and Wyoming, as well as the provinces of Alberta and Ontario, for sharing their snowmobile trail grooming training and educational materials and for allowing them to be incorporated into this project.

Special recognition is given to the many companies whose photos and/or materials have been used for demonstration purposes in this project. Sponsors of this project do not endorse products or manufacturers. Trade and manufacturer's names appear in this document only because they are considered essential to the object of the document.

The purpose of this publication is educational only, with no other intent but to expand snowmobiling and grooming professionals' knowledge base. It should not be assumed by the reader that all contributors agree with every written word, but are opinions only. The authors, contributors, FHWA, Trails Work Consulting, IASA, ACSA and their members accept no liability resulting from the compliance or noncompliance with the procedures or recommendations given herein, or for the accuracy or completeness of the information contained herein.

Snowmobilers must understand that snowmobile trails are not engineered roadways and therefore will not always be uniformly maintained with every potential hazard removed. Individual snowmobile operators and passengers must take responsibility for their own safe riding behavior, always being mindful that snowmobiling takes place in the unpredictable natural environment, and recognizing the effects of weather on trails.

The intent of publishing this document is to provide entities involved with snowmobile trail grooming a framework to train and certify their equipment operators. However, all decisions on local operator training content, as well as certification requirements, are reserved for implementation by local jurisdictions and local trail grooming managers consistent with local priorities and resources.

Copyright © 2005 Owned by the International Association of Snowmobile Administrators
All Rights Reserved.

TABLE OF CONTENTS

Acknowledgements	iii
List of Figures, Tables, and Photos with credits	vi
CHAPTER ONE – INTRODUCTION TO TRAIL GROOMING	1
Purpose of this Resource Guide	1
Groomer Operator Training – Core Components Checklist	3
Introduction to Snowmobile Trail Grooming	5
Trail Grooming Objective	8
The Physics of Snow and Snow Surface Preparation	9
Formation of Snow	9
The Snowpack and How It Changes	9
Grooming Snow, Physical Properties, and Metamorphism	11
Additional References on Snow Physics and Metamorphism	13
Trail Grooming Principles	14
Mogul Formation	14
The Four Steps of Trail Grooming	16
Step 1 – Removal of Moguls	16
Step 2 – Processing the Snow	17
Step 3 – Compression of the Processed Snow	19
Step 4 – Trail Set Up	20
Chapter Quiz	22
CHAPTER TWO – GROOMING EQUIPMENT	23
Grooming Drags	23
Multi-Blade Drags	24
Drag Width and Length	25
Typical Features of A Multi-Blade Drag	26
Frame	26
Side Rails and Spring Tripping Blades	27
Cutting Blades and Tongue	28
Compactor Pan and Skegs	29
Vibrating Pans	30
Wheel Assembly and Quick Release Features	31
Single Blade Drags	32
Tillers	33
Compactor Bars	35
Grooming Tractors	36
Grooming Tractor Components	37
Tracks	37
Steering, Engine, and Tractor Cab	38
Front Blade and Cargo Deck	39
Important Characteristics of Grooming Tractors	40
Ground Pressure and Overall Weight	40
Engine Horsepower and Torque	40
Center of Gravity, Tractive Effort & Coefficient of Friction	41

Snowmobiles and ATVs as Grooming Tractors	42
Chapter Quiz	43
CHAPTER THREE – MANAGING GROOMING OPERATIONS, EQUIPMENT, AND SAFETY	45
The Grooming Program Manager	45
Establishing Grooming Priorities	46
Operator Selection and Training	47
Operator Safety	48
Common Operator Guidelines and Policies	53
Preparing the Trail	54
Chapter Quiz	56
CHAPTER FOUR – OPERATING GROOMING EQUIPMENT	57
General Operating Guidelines	57
Grooming Basics	58
Tips for Effective Grooming With a Drag	61
Proper Use of the Front Blade	69
Tips for Grooming With a Tiller	70
Tips for Operating Tracked Vehicles	74
Tips on Avoiding Equipment Damage	75
Use It, Don’t Abuse It! – Ten Common Operator Abuses	76
Chapter Quiz	78
CHAPTER FIVE – MAINTAINING GROOMING EQUIPMENT	81
Preventative Maintenance	81
Types of Maintenance	82
General Tractor Maintenance Tips	84
Chapter Quiz	85
CHAPTER SIX – RECORD KEEPING	86
Recommended Forms	86
Chapter Quiz	87
CHAPTER SEVEN – RECOMMENDATIONS for GROOMER OPERATOR CERTIFICATION	88
Purpose and Who Should Be Certified?	88
How Long Should Certification Be Valid?	88
Levels of Operator Certification	88
Operator Certification Core Subjects	89
GLOSSARY OF TERMS	90
RESOURCES	92
REFERENCES	95
APPENDIX – SAMPLE FORMS	96
Weekly Grooming Schedule	97
Daily Grooming Log	98
Vehicle and Equipment Report	99
Vehicle/Equipment Monthly Maintenance Records	100
Grooming Equipment Maintenance Requests	101
Corrective Action Request	102
Groomer Operator Training Record	103

LIST of FIGURES, TABLES, and PHOTOS with credits

<u>Page</u>	<u>Figure/Table/Photo</u>	<u>Description</u>	<u>Credit</u>
Cover	Cover Photo	– Seney, Michigan trail groomers at work.	<i>Don Reed</i>
1	Photo 1.1	– Snowmobile traffic creates rough trails that require trail grooming.	<i>Kim Raap</i>
2	Photo 1.2	– Smooth, firm trails created by trail grooming. <i>Left: Bombardier, Right: Polaris</i>	
5	Photo 1.3	– Trail grooming is important to snowmobilers.	<i>Kim Raap</i>
5	Photo 1.4	– Riding styles like fast starts and powering through curves impact trails. <i>Left: Yamaha, Right: Arctic Cat</i>	
6	Photo 1.5	– Snowmobile grooming tractors share a history with Antarctic travel. <i>Left: Pistenraupen, Center: Trans Antarctic Expedition 1959, Right: Team Richard Snow Toys</i>	
6	Photo 1.6	– Typical specialized modern snowmobile trail grooming equipment. <i>Top: Tucker Sno-Cat, Bottom: Pisten Bully</i>	
7	Photo 1.7	– Examples of modern snowmobile trail grooming equipment. <i>Top, middle, and bottom right: Kim Raap; Bottom left: Pisten Bully</i>	
8	Photo 1.8	– Trail grooming builds a solid, compacted base.	<i>Kim Raap</i>
9	Figure 1.1	– The basic structure of snow formed in the atmosphere is a hexagonal crystal. A-axes growth produces a stellar crystal or “snowflake.”	<i>R.M. Lang</i>
10	Figure 1.2	– Equi-temperature metamorphism. Snow grains become rounded and bond to each other, producing a higher strength snow.	<i>R.M. Lang</i>
11	Figure 1.3	– Temperature gradient metamorphism. The flow of water vapor towards the colder snow surface causes the weak “depth hoar” to grow.	<i>R.M. Lang</i>
11	Figure 1.4	– Surface hoar crystals form on the snow surface during cold, clear nights.	<i>R.M. Lang</i>
13	Photo 1.9	– Example of a “boot test” that indicates a soft trail.	<i>Kim Raap</i>
14	Figure 1.5	– Mogul formation. <i>Ontario Federation of Snowmobile Clubs (OFSC), updated by JRJ Design (JRJ)</i>	
15	Photo 1.10	– Curves and areas where snowmobiles cut onto trails require special attention. <i>Left: Bombardier, Right: Polaris</i>	
15	Photo 1.11	– A snowmobile’s skis, track, and suspension all contribute to mogul formation.	<i>Yamaha</i>
17	Figure 1.6	– Step 1: Removal of moguls. The planer blade cutting depth should cut to the bottom of the mogul’s dip, but not into the compacted trail bed.	<i>OFSC, updated by JRJ</i>
18	Figure 1.7	– Step 2: Processing the snow. A churning action should be created in front of the planer blade to help process the compacted snow from the mogul into granules of various sizes.	<i>OFSC, updated by JRJ</i>
19	Figure 1.8	– Step 3: Compression of the processed snow. The loose snow created by the cutting and churning action of the blades is distributed by the spreader pan, then compressed into a new layer of compacted snow on the trail bed.	<i>OFSC, updated by JRJ</i>
20	Photo 1.12	– A freshly groomed trail that requires set up.	<i>Kim Raap</i>
21	Photo 1.13	– Try to groom at times when snowmobiles will not follow the groomer for best trail set up.	<i>Snow Country Groomers</i>
24	Photo 2.1	– Typical multi-blade drag.	<i>Kim Raap</i>
24	Figure 2.1	– Typical multi-blade drag design – top view.	<i>OFSC, updated by JRJ</i>
25	Figure 2.2	– Typical multi-blade drag design – side view with expanded view of cutting blades.	<i>JRJ Design</i>

- 25 **Photo 2.2** – Drag with hydraulic wings. *Kim Raap*
- 26 **Photo 2.3** – Typical multi-blade frames and blade configurations. *Left: The Shop Industrial (TSI), Right: LaCross Groomers*
- 27 **Photo 2.4** – Side rail on a multi-blade drag helps keep snow contained within the drag. *Kim Raap*
- 27 **Photo 2.5** – Spring tripping blades. *The Shop Industrial*
- 27 **Photo 2.6** – Spring shank blades. *Kim Raap*
- 28 **Photo 2.7** – Beveled cutting blades. *The Shop Industrial*
- 28 **Photo 2.8** – Serrated cutting blades. *The Shop Industrial*
- 28 **Photo 2.9** – Pivoting tongue. *The Shop Industrial*
- 28 **Photo 2.10** – Rigid steer hitch. *Ebert Welding*
- 29 **Photo 2.11** – Angled front of pan. *The Shop Industrial*
- 29 **Photo 2.12** – Radius lip on rear of pan. *The Shop Industrial*
- 29 **Photo 2.13** – Skeg marks on a freshly groomed trail. *Kim Raap*
- 30 **Photo 2.14** – Typical vibrating rear pans. *Top: Kim Raap, Bottom: Ebert Welding*
- 31 **Photo 2.15** – Typical wheel assemblies. *Left: The Shop Industrial, Right: Kim Raap*
- 31 **Photo 2.16** – Typical rear drum roller assembly. *Maine Department of Conservation*
- 31 **Photo 2.17** – Quick-release couplings and shear pin in tongue of pintle hitch. *Kim Raap*
- 32 **Photo 2.18** – Typical single blade drag. *Kim Raap*
- 32 **Photo 2.19** – Typical single cutting blade. *Kim Raap*
- 33 **Photo 2.20** – Typical rear-mounted tiller. *Pisten Bully*
- 33 **Photo 2.21** – View of the underside of a tiller. *Pisten Bully*
- 34 **Photo 2.22** – Flex tiller set in a rigid (straight) position with lockout device shown below. *Pisten Bully*
- 34 **Photo 2.23** – Flex tiller lockout device. *Pisten Bully*
- 35 **Photo 2.24** – Typical compactor bars. *Left: Track, Inc., Left: The Shop Industrial*
- 36 **Photo 2.25** – Typical grooming tractors. *Top Left: Camoplast/Bombardier, Top Right: AFMI Industrial, Center: Pisten Bully, Bottom Left: Tucker Sno-Cat, Bottom Right: VMC Right Track*
- 37 **Figure 2.3** – Typical components of a grooming tractor. *OFSC*
- 38 **Photo 2.26** – Example of a steel-cleated track. *Cook’s Equipment, Inc.*
- 38 **Photo 2.27** – Example of a rubber track. *Kim Raap*
- 38 **Photo 2.28** – Typical controls in a tractor’s cab. *Left: Tucker Sno-Cat, Right: Ebert Welding*
- 39 **Photo 2.29** – Typical front blade at work. *Kim Raap*
- 39 **Photo 2.30** – Typical rear deck used to carry tools, spare signs, and spare fuel. *Kim Raap*
- 41 **Figure 2.4** – Center of gravity for a typical 2-track grooming tractor. *OFSC*
- 42 **Photo 2.31** – Typical snowmobile powered grooming unit. *Right and Left: TSI*
- 42 **Photo 2.32** – Typical ATV powered unit. *New Hampshire (NH) Bureau of Trails*
- 47 **Photo 3.1** – Operator training is important and should include hands-on in-shop instruction. *Kim Raap*
- 51 **Photo 3.2** – Stop only where there is good site distance. *New Hampshire Bureau of Trails*
- 51 **Figure 3.1** – Use warning devices like traffic cones, flares, crossed poles, or flagging to warn snowmobilers of parked groomers and on-trail hazards. *NH Bureau of Trails*
- 51 **Photo 3.3** – Place cones or other warning devices around and in advance of a groomer that has broken down on the trail and must remain there for an extended period. *New Hampshire Bureau of Trails*
- 52 **Photo 3.4** – Beware that collisions may be with the groomer! *NH Bureau of Trails*
- 53 **Photo 3.5** – The operators of this groomer were smoking marijuana and drove off the bridge. *Maine Department of Conservation*

- 54 **Photo 3.6** – Trail maintenance prior to snowfall can help make trails smoother in the winter. *Kim Raap*
- 55 **Photo 3.7** – It is easier to remove stumps, brush, and debris before snowfall accumulates. *Wyoming State Trails Program*
- 59 **Photo 4.1** – Always groom on the right side of the trail. *Kim Raap*
- 59 **Photo 4.2** – Use the rearview mirrors to constantly watch behind the groomer to monitor the quality of the finished trail. *Kim Raap*
- 60 **Photo 4.3** – Remove back up piles! Use SMV sign. *Kim Raap*
- 61 **Photo 4.4** – Don't leave holes in the trail. *Kim Raap*
- 62 **Photo 4.5** – Keep processed snow inside the drag! *Kim Raap*
- 63 **Photo 4.6** – Remove debris from trail. *Kim Raap*
- 64 **Photo 4.7** – Never leave piles of snow on roads. *Maine Department of Conservation*
- 64 **Photo 4.8** – Always raise the drag to cross roads. *Kim Raap*
- 64 **Photo 4.9** – Use care to not create snow/ice buildup on railroad tracks. *Maine Department of Conservation*
- 65 **Photo 4.10** – Use only the rear set of blades to groom minimally moguled trails. *Kim Raap*
- 65 **Photo 4.11** – Don't leave a hazardous pile of snow in the trail when adjusting the drag. *Kim Raap*
- 67 **Photo 4.12** – The crest of a hill often needs snow. *Kim Raap*
- 67 **Photo 4.13** – Beware of trenches dug by spinning tracks. *Kim Raap*
- 68 **Photo 4.14** – Sharp curves typically have little snow available at the inside/bottom. *Kim Raap*
- 69 **Photo 4.15** – Watch *behind* the front blade to monitor blade height relative to track location. *Kim Raap*
- 72 **Photo 4.16** – Properly finished trail. *Pisten Bully*
- 83 **Table 5.1** – Sample Grooming Drag Maintenance Checklist. *The Shop Industrial*

Chapter One:

INTRODUCTION TO TRAIL GROOMING

Purpose of this Resource Guide

The purpose of this resource guide is to provide snowmobiling agencies, associations, and clubs with guidelines that are a resource for:

- grooming recreational snowmobile trails to help improve the quality of trails and the effectiveness of grooming efforts and expenditures;
- training snowmobile trail groomer operators on the proper operation and maintenance of grooming equipment; proper trail grooming objectives, principles, and practices; and trail grooming safety issues; and
- increasing community awareness of snowmobile trail grooming requirements and practices, including the need for the public to allow proper set up time on freshly groomed trails and safe operating procedures for snowmobilers when encountering groomers on the trail.



Photo 1.1 Snowmobile traffic creates rough trails that require trail grooming

A growing number of snowmobiles are operating on snowmobile trails today, which drives an increasing need for smooth trails that can keep traffic moving safely. This makes it necessary to optimize the use of personnel and equipment involved with trail grooming. Increased operational costs have also necessitated tighter controls on grooming operations to maximize the effectiveness of expenditures. Certainly, grooming under conditions that do not allow snowmobile trails to properly set up is not

advantageous or effective. This resource guide is intended to help grooming managers and operators recognize various scenarios to help them optimize their effectiveness under as many winter conditions as possible.



Photo 1.2 Smooth, firm trails created by trail grooming

Historically, area decisions regarding grooming scheduling have sometimes been driven by perspectives like “the public demands that we groom during the day so they can see the groomer,” or “the groomer operators are volunteers, so they need to groom fast so they can get back home.” Neither situation tends to produce effective grooming. Scheduling productive and effective grooming operations can be challenging, particularly in areas where there is no “slow time” and snowmobile traffic is heavy every day of the week. Grooming managers are continually challenged to make their grooming resources go further to keep up with the ever increasing demand for smooth trails.

This guide is but one tool to assist with the development and maintenance of safer, smoother snowmobile trails. The materials within are intended as general guidelines that may not apply to every local situation or condition and are not intended to be all encompassing. At the same time, the materials within cover basic yet important grooming fundamentals and principles and also provide valuable tips that can help areas improve the quality, and durability, of their snowmobile trail systems if applied correctly.

Snowmobile trail grooming times, frequencies, and methods can be influenced by many variables including: temperature, type and depth of snow, terrain, snowmobile traffic volume and use patterns, wind, current or incoming storms, and avalanche or water crossing hazards. Decisions as to when to groom and the implements to use should be based upon the informed judgment of the local grooming manager, following guidelines and principles outlined in this guide along with guidance and program-wide stipulations from jurisdictional or governmental program administrators who typically control local funding levels.

The *Groomer Operator Training Core Components Checklist* on the following pages outlines topics that are important for groomer operators to know and understand and provides a snapshot of the topics covered more in-depth by this resource guide.

GROOMER OPERATOR TRAINING

Core Components Checklist

Every Groomer Operator Should Be Able To:

- 1. Demonstrate an Understanding of the Basics of Snowmobile Trail Grooming.**
 - Understand trail grooming's general purpose, objectives, principles, and practices, along with common terms used in trail grooming.
 - Understand the basic characteristics and mechanics of snow.
 - Understand the role and importance of grooming managers and schedules.
 - Understand the source and level of funding for their snowmobile trails.

- 2. Know the Grooming Equipment they are Operating and Identify its Key Controls, Components, and Features.**
 - Know the capabilities, characteristics, and limitations of their grooming tractor and front blade.
 - Identify key controls and components of their grooming tractor and front blade (steering, throttle, brakes, lights, mirrors, hydraulics, tracks, engine, hitch, etc.)
 - Know the capabilities, characteristics, and limitations of their grooming implement(s) (drag, tiller, or compactor bar as applicable).
 - Identify key features of their grooming implements (frame, blades, wheels, tongue, hydraulics, skags, pan, tines, drum, lights, etc. as applicable)

- 3. Start, Operate, And Control the Groomer.**
 - Properly conduct a pre- and post-operation visual inspection.
 - Operate and understand all in-cab controls, instruments, and gauges.
 - Start, stop, and park the vehicle.
 - Back up the vehicle and hook it up to implements.
 - Operate the vehicle on the right side of the trail.
 - Demonstrate proper technique to get the vehicle unstuck.
 - Demonstrate front blade functions and operation.
 - Demonstrate the function and operation of rear implements.

- 4. Demonstrate Good Operator Safety Procedures.**
 - Be prepared by carrying tools, safety equipment, and proper clothing.
 - Ensure grooming equipment is always visible with lights and reflective material.
 - Always wear seat belts and operate cautiously when using front blade.
 - File trip plan and stay in communication with dispatch or manager.

- Safely stop and park grooming equipment when on trail.
- Safely secure grooming equipment that breaks down on the trail.
- Avoid ice crossings.
- Check equipment prior to departure.
- Carry extra trail signs and replace when missing.

5. Demonstrate Proper Equipment Operation Techniques and Procedures.

- Understand general grooming operating guidelines, including minimum snow depth, best time to groom, the optimal temperature range for grooming, and grooming procedures for when there is low visibility.
- Understand grooming basics like: constantly watching the trail behind the groomer; don't leave holes, debris, or back-up piles on the trail; and know your trail so you can anticipate grooming needs and adjustments.
- Understand proper grooming speed and problems caused by grooming too fast.
- Understand the proper technique for grooming curves, hills, and bridges.
- Understand the difference between building and maintaining a trail base.
- Understand what to do when meeting snowmobiles on the trail.
- Understand proper grooming width and direction of travel.
- Understand proper techniques for grooming with a drag.
- Understand proper techniques for grooming with a tiller.
- Understand proper techniques for use of a front blade.
- Understand proper techniques and tips for operating tracked vehicles.
- Know the Top 10 Operator Abuses

6. Perform Proper Equipment Inspection and Maintenance.

- Understand the importance of preventative maintenance.
- Practice the Four Elements of Preventative Maintenance.
- Refuel and lubricate the equipment.
- Perform pre-shift inspection and maintenance.
- Periodically stop to perform walk-around inspection during grooming shift.
- Perform post-shift inspection and maintenance.
- Notify grooming manager of equipment maintenance needs.
- Assist with pre-season, off-season, and regularly scheduled maintenance as requested.

7. Perform Proper Record Keeping.

- Complete Daily Groomer Operator's Logs and Pre- and Post Operation Checklists.
- Keep accurate records of equipment use and maintenance.
- Submit Equipment Maintenance Requests and Corrective Action forms.

8. Know the Local Area and Local Procedures.

- Know local trail routes and have maps available for snowmobilers.
- Know local trail signing guidelines.
- Know local laws and any special closures for sensitive areas.
- Know local emergency procedures and contact information.

Introduction to Snowmobile Trail Grooming

A snowmobiler's safety and enjoyment is greatly enhanced when a smooth, even layer of snow covers the trail they have chosen to ride.

“Trail grooming” is the activity of producing a smooth surface of snow with a uniform high density through the use of mechanical equipment. Trails become rough primarily through the cumulative effects of snowmobile traffic.



Weather can also have a considerable impact on trail quality,

Photo 1.3 Trail grooming is important to snowmobilers as can the effects of other trail users, water movement, timber operations, etc.

Snowmobile riders are very aware of the importance of trail grooming since it has a very fundamental impact upon the enjoyment of their ride. Consequently, the general interest in good trail grooming is high throughout the snowmobiling community, including businesses that cater to snowmobilers. At the same time, the actions of and the equipment used by snowmobile riders – fast starts or stops, powering through curves, carbide runners, paddle tracks, and powerful engines – can combine to have great impacts upon



Photo 1.4 Aggressive riding styles like fast starts and powering through curves impact trails

the conditions of snowmobile trails and can essentially destroy them in a very short period of time.

Trail grooming is typically the single greatest expense facing the operation of a snowmobile trail system, both in terms of capital costs to purchase expensive equipment as well as for the ongoing costs of operating and maintaining that equipment in harsh winter conditions. In many areas, trail grooming is often the main focus of a snowmobile club or association's activities. It can account for as much as 50% to 75% of total expenditures for agency or association operated snowmobile programs. It is big business.



Photo 1.5 Snowmobile grooming tractors share a history with Antarctic travel
Snowmobile trail grooming equipment shares a common history with tracked vehicles originally developed for Antarctic travel and for the alpine ski industry. However, in the mid-1980s a number of changes began to evolve in snowmobile trail grooming tractors and drags that have greatly increased the effectiveness of today's snowmobile grooming equipment. While there is still some crossover today between alpine ski and snowmobile trail grooming equipment, snowmobile trail grooming equipment has evolved to be a specialty product that stands on its own.



Photo 1.6 Typical specialized modern snowmobile trail grooming equipment

The grooming tractor is a heavy-duty, two or four-tracked vehicle whose primary purpose is to provide the power to pull an implement (drag), power a tiller, or carry a compactor bar across the top of the snow. It may also be used to carry a front blade. Some areas also use farm tractors equipped with a track conversion to pull grooming drags.



Photo 1.7 Examples of modern snowmobile trail grooming equipment

The actual work of grooming the snow on the trail bed is performed by a front blade used in conjunction with implements like a drag or tiller that are either towed or carried behind the tractor. While a grooming drag is called a planer or a surfacer by some manufacturers, it will be referred to simply as a drag in this document. Tractors, tillers, drags, and other grooming implements will be discussed in depth in Chapter 2.

TRAIL GROOMING OBJECTIVE

The overall objective of snowmobile trail grooming is to provide smooth trails that are suitable for all levels of rider experience. This can mean many things: establishing a trail base at the beginning of the season, having to reestablish a trail after heavy snowfall and/or winds have obliterated it, or having to work a heavily moguled trail back into a smooth surface (also called “restoring” the trail).

Throughout the season, the key to successful trail grooming is for the groomer to build a solid base of snow “pavement” for snowmobiles and grooming equipment to operate upon. The groomed trail base will be packed solid from the ground up while the snow off to the side of the trail will generally be soft and may be several feet deep. This means that both snowmobiles and the grooming equipment can become stuck should they venture off the packed trail base in deep snow areas. As a groomer operator, the trail is your friend – know where it is and stay on it!

It is important to understand the minimum level “grooming frequency” or “grooming standard” that is established for trails in an area. It is always driven by the available budget and results in priorities needing to be set. As a result, it is likely that all trails in an area may not receive the same minimum level of weekly grooming repetitions. Some areas categorize their trails as Level 1, 2, or 3. In this example, Level 1 or “Minimum” trails have no commitments for grooming. Level 2 or “Preferred” trails are fully “restored” at least once every 5 days. Level 3 or “Comprehensive” trails are fully restored at least once every 3 days. If categories like these are used, it is important that, 1) equipment operators and snowmobilers in the area understand the expectations, and 2) the grooming program and operators follow through with the expected commitment.



Photo 1.8 Trail grooming builds a solid, compacted base

THE PHYSICS of SNOW and SNOW SURFACE PREPARATION

It is useful for grooming managers and grooming equipment operators to have a basic understanding of the properties of snow in order to produce and maintain a durable trail. Because snow (or ice) on the Earth's surface exists so close to its melting temperature, it is unlike soils or other construction materials used to build or surface trails. This section presents a general overview of how snow forms in the atmosphere, its response to environment, and external loads that are important to snowmobile trail grooming.

Formation of Snow

The basic structure of snow, or ice, is a hexagonal (six-sided) crystal within Earth's atmospheric pressures and temperatures (see Figure 1.1). Three a-axes are perpendicular to the c-axis at 60° to each other. The direction of crystal growth along the c-axis or a-axes depends on temperature. This temperature dependence of crystal growth produces the wide variety in the geometric forms of snow, such as stellar crystals, plates, dendrites, needles, columns, etc. Prolonged rotation of a snow crystal in the atmosphere produces more irregularly shaped aggregations of crystals such as snow pellets or sleet.

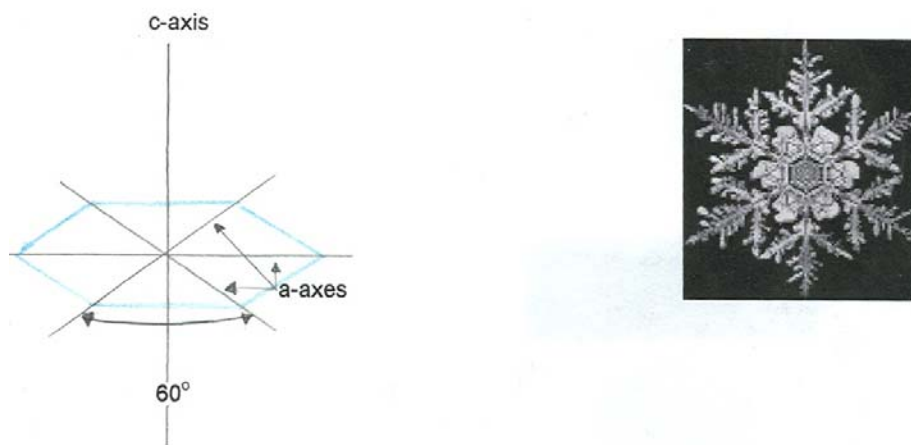

Figure 1.1 The basic structure of snow formed in the atmosphere is a hexagonal crystal. A-axes growth produces a stellar crystal or “snowflake”.

The Snowpack and How It Changes

Once snow has been deposited on the ground, it begins to change, or metamorphose. Gravity causes natural compaction and motion (or creep) to occur. Water vapor moves from areas of higher temperature or higher pressure areas to lower temperature or lower pressure areas. Free water may be present in the snowpack and solar radiation can cause a change in the snow surface.

Three basic types of changes in the snowpack, i.e. snow metamorphism, are important for the groomer operator to understand. These changes depend mostly on the snow

temperatures, allowing water vapor to flow within the snowpack, or the migration of free water in the snowpack. It is important to note that the temperature of the snow, even at or near the snow surface, is not typically the same as the ambient air temperature.

Equi-temperature (ET) metamorphism occurs in regions where an “equal” or uniform temperature is present within the snowpack. This produces a high degree of sintering (neck growth and bonding) which yields a higher strength snow. The snow crystals grow, become rounded, and bond at the expense of more faceted forms due to the transport of water vapor.

Under equal temperature conditions, the transportation of water vapor is a pressure dominated process (see Figure 1.2). Higher vapor pressures are present over convex surfaces. Lower vapor pressures exist within concave surfaces. The water vapor at high pressure moves to the low pressure regions, condenses, and forms necks and bonds. This is the desired condition for producing a stronger, more durable snow surface.

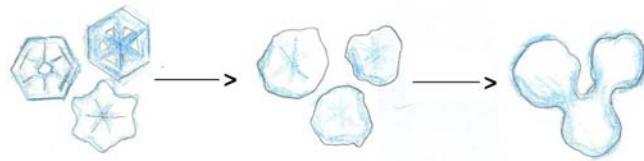
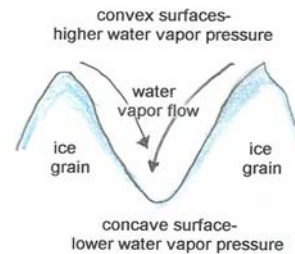

Figure 1.2 Equi-temperature metamorphism. Snow grains become rounded and bond to each other, producing a higher strength snow.



Temperature gradient (TG) metamorphism causes the formation of a poorly bonded, faceted TG crystal, commonly known as “depth hoar.” It is typically seen at the base of the snowpack or underneath an ice crust layer. The formation of a TG layer typically occurs in a shallow snowpack during cold, clear nights. The heat loss of the snow surface to the atmosphere through radiation creates a strong temperature gradient, or temperature difference, within the snowpack. The ground temperature will be warmer than the snow surface temperature. A weak, hollow layer will be formed and will persist at the base of the snow.

Under temperature gradient conditions, water vapor transport is dominated by temperature (see Figure 1.3 on the next page). Water vapor at the higher ground temperature moves upward to the lower snow surface temperature, or more simply, hot moves to cold. When the net vapor transport is toward the snow surface, faceted cohesionless crystals rapidly form due to the excess vapor density. It is important for the groomer operator to note a weather pattern of cold, clear nights with a shallow snowpack

early in the season, particularly in mountainous regions, since the presence of a TG layer at the base of the snowpack can eventually produce an avalanche cycle.

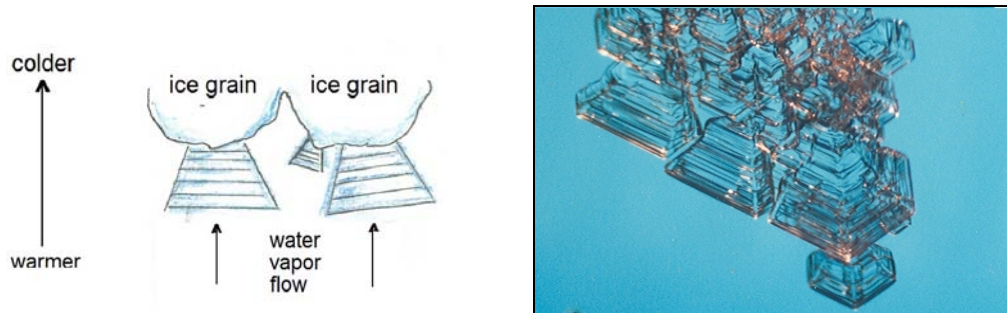

Figure 1.3 Temperature gradient metamorphism – the flow of water vapor towards the colder snow surface causes the weak “depth hoar” to grow.

Cold, clear nights following the passage of a front can also cause changes on the snow surface. The development of surface hoar occurs when a temperature gradient, or difference, between the atmosphere and the snow surface develops. Again, hot moves to cold, so water vapor is driven from the atmosphere to the cooling snow surface, forming the cohesionless faceted surface hoar crystals (see Figure 1.4). Again, these crystals are very stable within the snowpack, and a layer of these weak crystals can persist over the entire winter season.

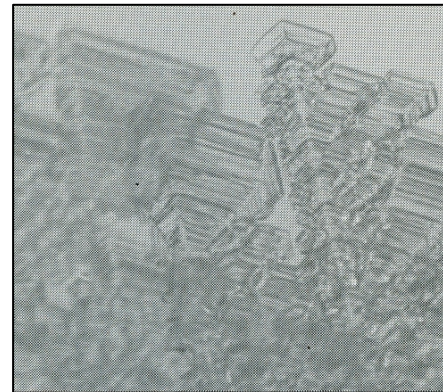

Figure 1.4 Surface hoar crystals form on the snow surface during cold, clear nights.

Melt-freeze (MF) metamorphism occurs whenever free water is present within the snowpack. Free water may be present due to a rain event or surface melting by solar radiation. Free water will percolate slowly through the snow and freeze within a colder region of the snowpack. Near the snow surface, smaller grains will melt and the melt water will be retained by the surface tension of the larger grains. Refreezing forms larger, polygranular clusters. The snow strength becomes increasingly dependent upon the degree of refreezing that occurs. Melt-freeze snow can become solid ice or completely de-bonded, depending on its temperature.

Grooming Snow, Physical Properties, and Metamorphism

Regional and seasonal differences in snow quality (i.e. physical properties of snow such as particle size, wetness, density, temperature, etc.) will influence the ideal method for trail preparation. In general, the goal of trail grooming is to reduce the snow particle size and produce some different particle sizes in order to maximize the number of bonding, or

sintering, sites within the snow. Mixing a layer of snow should also temporarily produce an equal temperature layer, to some extent. In other words, the goal is to prepare a layer of the snow to maximize equi-temperature metamorphism within that layer, and allow sufficient time for bonds to form between the snow grains, i.e. “set-up.” Therefore, the overall quality, or physical properties, of the snow prior to and post-grooming are of some importance.

For grooming, the most important indicator properties of the snow are particle size, temperature, wetness, and the final snow hardness, or strength. Snow density, or the mass per unit volume of the snow, is not necessarily a good indicator property of snow strength since very wet, unbonded, melt-freeze snow can be of very high density but have very low strength.

The particle size and sorting can be determined by simply examining the snow prior to grooming. A particle size range from 1/32 in. to 3/16 in. (0.5 mm to 4.5 mm) is ideal. Large particles or clumps that have developed perhaps due to melt-freeze changes (MF metamorphism), may require a more aggressive grooming technique, such as tilling the snow. In many regions, the snowfall consists of relatively low density, small particulate snow and the snowpack remains dry. In such areas, a multi-blade drag can provide sufficient remixing of the snow surface. It is important for the groomer operator to become familiar with the variations in snow particle sizes for his/her specific region and snow conditions in order to determine the appropriate grooming technique.

For bonding to occur, the snow temperature must be below freezing, i.e., less than 32° F or 0° C. Again, equi-temperature metamorphism is a water vapor pressure dominated process, so water vapor is probably more available for vapor transport in warmer snow. This only implies that bonding may occur at a more rapid rate when the processed snow is only a few degrees below freezing. Well-bonded snow can be achieved at very cold temperatures (less than -40° F or -40° C). The critical factor is allowing sufficient time for the snow to sinter, or “set up.” It is highly recommended that grooming occur post-sunset, as the snow surface does absorb some solar radiation during the day which will increase the snow surface temperature. An equi-temperature metamorphism condition, and therefore better conditions for trail set up, is more easily achieved after sunset.

Relatively inexpensive rapid response digital thermometers are commercially available for snow temperature measurements. Infrared temperature sensors are not recommended since solar radiation, the reflection of the snow surface, and the exhaust from the grooming vehicle can produce an inaccurate temperature measurement.

The free water content of the snow, or wetness of the snow, can influence the selection of the best method for processing the snow. This property is best determined by measuring the snow temperature. The groomer operator should examine the snow, by trying to make a snowball, for example. Very warm, wet, or saturated, snow will not be cohesive. However, if the temperature is dropping wet snow may refreeze overnight. Also, freshly fallen, cold, dry snow will not readily stick together. However, grooming and compacting this type of snow will enhance its ability to form bonds or “setup.”

Snow hardness is the best indicator property for snow strength. There are many available methods for testing hardness, such as cone penetrometers, ram penetrometers, drop tests, etc. For the groomer operator, simply walking or stomping on the snow with a simple “boot test” (see Photo 1.9) is probably sufficient to give an indication of the compressive strength of the snow. When boots make a deep imprint, the snow is soft. A light imprint indicates a medium strength snow. When it is difficult to imprint the snow at all, the trail can be considered hard and grooming is working well. Another simple means for the groomer operator to get an indication of strength from within the cab of the tractor is to watch the ski imprint of the last snowmobile traveling the trail. If the body of the ski is sinking into the surface, the trail is soft. If the skag is riding on the surface, it is hard.



Photo 1.9 Example of a “boot test” that indicates a soft trail

Additional References on Snow Physics and Metamorphism

For more detailed information regarding Snow Physics, refer to:

International Classification for Seasonal Snow on the Ground; COLBECK, S.C., ET AL. *Int. Commission on Snow and ice of the Int. Assn. of Sci. Hydrology* 37 pp. 1990.
www.crrel.usace.army.mil/techpub/CRREL_Reports/reports/Seasonal_Snow.pdf.

Snow Roads and Runways; ABELE, G. *CRREL monograph 90-3*, 100 p. 1990.

Processing Snow for High Strength Roads and Runways; LANG, R.M., BLAISDELL, G.L., D'URSO C., REINEMER, G., LESHER, M. *Cold Regions Sci. & Tech.*, Vol. 25, Issue 1, pp 17-31. 1997.

For a more detailed discussion of snow metamorphism, refer to: The Avalanche Handbook; MCCLUNG, D.M. AND SCHEARER, P. *The Mountaineers*, 266 pp. 1993.

TRAIL GROOMING PRINCIPLES

It is important that the basic principles of snowmobile trail grooming are understood in order to properly operate trail grooming equipment and achieve the desired result of smooth, firm trails. Working a heavily moguled trail back into a smooth surface, that will last, is probably the most difficult aspect of trail grooming. To accomplish this successfully, it is important to understand the characteristics of moguls.

Mogul Formation

The primary reason snowmobile trail grooming is necessary is the continuous formation of moguls by passing snowmobile traffic. Moguls are patterns of mounds and dips formed in the trail's snow surface perpendicular to the direction of snowmobile travel.

Moguls in snowmobile trails are caused by passing snowmobiles just as “washboards” are created in gravel roads by passing vehicles. Gravel roads have to regularly be graded. Similarly, snowmobile trails must be regularly groomed. Moguls are as undesirable to snowmobilers as washboards are to motorists.

Figure 1.5 demonstrates how moguls are formed. In the top view, a small rut is created in the trail by a snowmobile that has either braked suddenly or accelerated too quickly. Views 2, 3, and 4 show how the rut develops into a run of moguls as the suspensions of many successive snowmobiles react to the uneven trail surface, each one compounding the other, as each snowmobile passes.

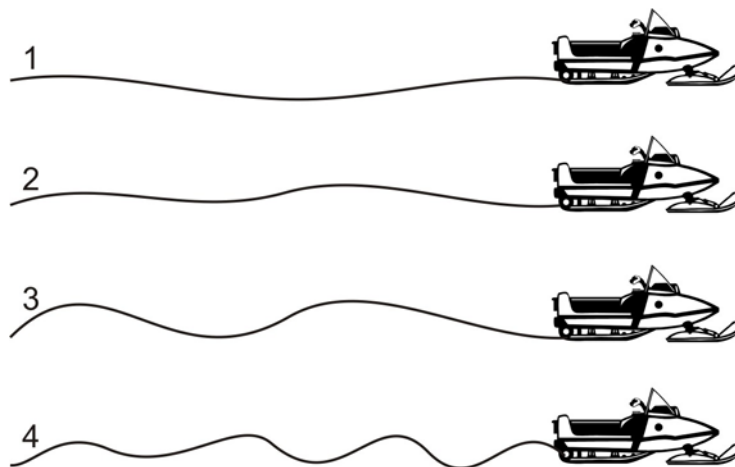

Figure 1.5 Mogul formation

Today's modern snowmobile, with its carbide runners that cut the snow surface and up to two-inch deep track lugs that dig out the snow, is an unintentionally effective digging machine. As a result, snowmobile riders innocently destroy the surface they desire to be smooth. Moguls tend to form wherever snowmobiles accelerate quickly or slow down abruptly. This can include before and after curves, approaching and leaving stop signs, before and after bridges, or on steep hills. These areas all require extra attention by the groomer operator.



Photo 1.10 Curves and areas where snowmobiles cut onto trails require special attention

Moguls also tend to form in long, coherent stretches or runs on relatively flat, open sections of trail. Each passing snowmobile, as the suspension extends and contracts, causes the mounds to get higher and the dips to get deeper the same distance apart from one another in a constant, unchanging rhythm that pounds both machine and rider and makes the ride most unpleasant. And the greater the speed, the more suspensions will expand and contract.

In these locations, it can be important that a drag, with its length and planer effect, is used to level the trail versus trying to “groom” with the front tractor blade, which can often further accentuate the rhythm of this type of moguling.



Photo 1.11 A snowmobile's skis, track, and suspension all contribute to mogul formation

Moguls can also be caused by “natural formation” in situations where there is warm ground or creeks under the snow, as well as by the alternating effects of sun and shade.

THE FOUR STEPS OF TRAIL GROOMING

The primary purpose of grooming is to remove moguls and compact the trail base. This is not simply a matter of knocking off part of one mound and pushing the displaced snow into the adjacent dip. A “cut-and-fill” grooming operation produces an uneven snow density that can result in a poor riding experience. Even though the trail may initially look smooth, the trail will most likely quickly revert back to moguls as the soft snow is pounded out of the filled dips by passing snowmobiles.

Four basic operations are required to produce a well groomed trail that is durable. They include: Step 1 – Removal of Moguls, Step 2 – Processing the Snow, Step 3 – Compression of the Processed Snow, and Step 4 – Trail Set Up. In most cases, grooming with a multi-blade drag will produce results superior to grooming with a single blade drag or a tiller since a multi-blade drag generally does a good job of accomplishing all four steps while a single blade drag or tiller accomplishes some steps better than others. For this reason, a multi-blade drag has been chosen to demonstrate the four grooming steps.

Step 1 – Removal of Moguls

Ideally, moguls should be completely cut away from the snow that forms the trail base. Beware that if the top is simply cut off a mound and dropped into the depression of the adjacent dip, it can result in the same mogul returning in no time at all. By completely removing the mound, all the way down to the bottom of the adjacent dip, the profile of the mogul is eliminated from the trail.

However, also beware to not cut into the layer of snow that forms the compressed trail base below the bottom of a mogul’s dip. The mogul should be removed, but not the solid trail base below it, so care must be given to cutting no deeper than the bottom of the dips that form the moguls. This requires that the cutting depth must be continually monitored and adjusted by the Groomer Operator.

There may be limitations to successfully removing the entire mogul: 1) if there is bare ground showing at the bottom of the dips in the moguls, do not attempt to cut the whole mound off since it could damage the equipment and result in destroying whatever hardened trail base there is; 2) if using a single blade drag and the moguls are deep, it is likely that snow could be lost out the sides of the drag when cutting deep enough with the blade to successfully remove the entire mogul. In this situation it is better to “save” the snow on the trail base rather than spilling it out the side where it may be “lost” for the purposes of grooming; 3) if using a tiller, the front blade on the tractor is the most effective tool for mogul removal prior to processing the snow with the tiller. However this has limitations since it cannot duplicate the planer effect of a drag; and 4) if using a multi-blade drag, it will not cut any deeper than the depth that the planer blades extend below the bottom of the side rails of the drag when it is fully lowered. If the trail bed is soft, the side rails may cut into the trail bed. But if the trail bed is hard, the rails will typically ride on top and limit the cutting depth. In all cases, the goal should be to remove all, or as much of the mogul as is reasonably possible, to produce a trail that will stand up

better to snowmobiling traffic. Oftentimes, multiple grooming passes may be required to achieve this.

Multi-blade drags accomplish mogul removal by using multiple sets of planer blades angled to cut *into* the moguls. As shown in Figure 1.6, the preset cutting depth of the planer blades are typically stepped slightly lower from the front to the rear of the drag, which results in the deepest cutting depth when the drag is fully lowered so it rides flat on the side rails. Again, if the depth of the moguls exceeds the depth of the drag blades, multiple passes may be required to accomplish complete mogul removal.

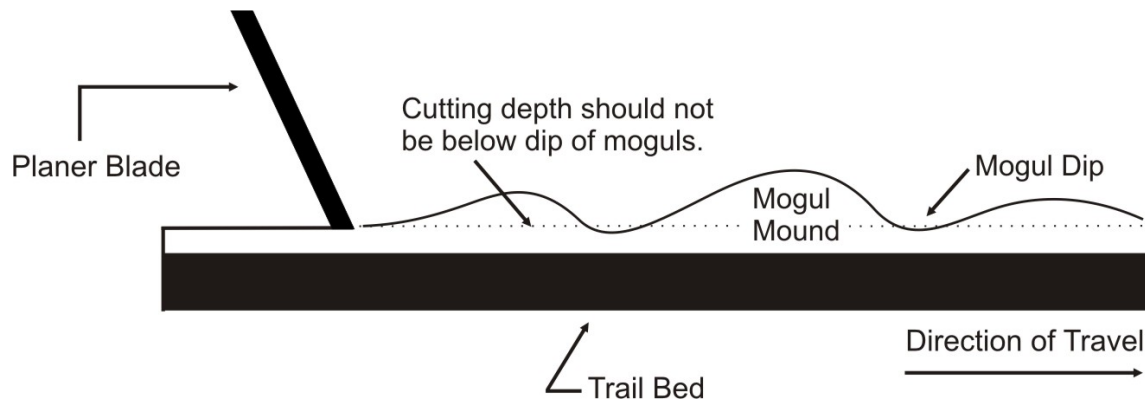

Figure 1.6 Step 1: Removal of moguls. The planer blade cutting depth should cut to the bottom of the mogul's dip, but not into the compacted trail bed.

When deep, fresh snowfall covers moguls on the trail, it may not always be possible or practical to completely remove the moguls. In such a case, it is critical that extra attention is given to Steps 2, 3, and 4 outlined below since a new, hardened trail base must be created to cover the profile of old moguls below the new layer of snow.

Step 2 – Processing the Snow

At any given time, there may be several types of snow on a snowmobile trail – hard packed snow, soft snow, wet snow, dry snow, ice, freshly fallen snow, wind blown snow that is typically small granules and some of the hardest snow, or snow that has been pounded by snowmobiles and worked so hard by groomers that there is little consistency left in it. It is critical that all types of snow be “processed” to achieve proper trail compression and set up.

As shown in Figure 1.7, snow processing is accomplished by the establishment of a rolling or churning action in front of the blades as they move forward at a correct and constant speed. In many drag designs, the multiple blades are angled so the snow moves from side to side further mixing and homogenizing it. While the snow is being mixed, it is also de-aerated (air space between snow particles is removed to make it denser). When using a single blade drag, it is critical that this rolling action is achieved since there is only one blade/one shot at properly processing the snow. While a tiller does an excellent job of processing snow, it can be limited by the depth of its tines.

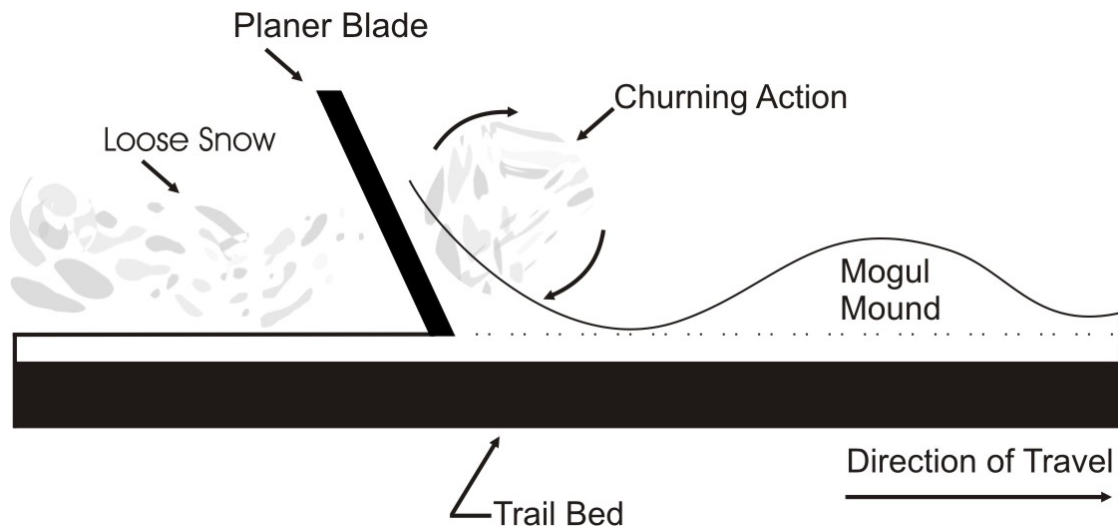

Figure 1.7 Step 2: Processing the snow. A churning action should be created in front of the planer blade to help process the compacted snow from the mogul into granules of various sizes.

This churning, tumbling, or milling action removes air from the snow and, at the same time, breaks up the compacted snow from which moguls are formed into smaller granules of various sizes. It also breaks away points from individual snow flakes so they can be compressed more tightly.

The mechanical action of the churning and tumbling has another important purpose in that it can sometimes introduce moisture into the snow mix due to friction. This friction causes the temperature of the snow to actually rise, be it a very small fraction of a degree, which can create a small amount of moisture in the processed snow. This is especially valuable when snow is very dry. Introducing this moisture into the processed snow is also very important to the success of Step 4, achieving good trail “set up.”

It is critical that the rolling or churning action is achieved. If snow is allowed to ball up or plow along in front of the blades without this rolling action, the snow is not being properly processed (doesn't de-aerate, doesn't mix and break points, doesn't produce friction). This can be caused by the tractor traveling too fast (not enough time for the snow to properly roll and process), grooming conditions being too warm or too wet, or improper drag blade height (set too deep if “plowing” or too shallow if no snow in blade).

The height of the drag's blade(s) is critical to proper processing of the snow. If the trail is fairly smooth or only slightly moguled, only a minimum of snow will need to be processed since it isn't desirable to disturb any more of the trail base than what is needed to remove the moguls. In such cases, there may only be a need to have snow churning in the rear sets of blades on a multi-blade or only a partial blade full on a single blade. If the trail is heavily moguled or if there is lots of new snow, more blades on the multi or greater depth on the single blade will likely be required. Remember – process only as much as is needed to remove the moguls, but no more.

Proper ground speed is also critical to proper processing of the snow. Too slow and the proper churning, rolling, and mixing to produce the friction that is needed to improve trail set up is not achieved. Too fast and several factors work against effective grooming, particularly with multi-blade drags. First, too high of a ground speed results in the angled blades spraying snow out the sides of the drag where it is lost and wasted for the purposes of grooming. Snow is precious to the grooming operation and most areas can ill afford to deliberately throw it off the trail. Second, the rolling and churning action is partially dependant upon forces of gravity, so proper time must be allowed for the snow to roll, churn, and fall out. Third, going too fast can sometimes, in effect, over-process the snow and prematurely wear it out. Processing snow can be similar to using a blender – low to mid speeds can achieve good mixing and blending, but setting the speed too high can actually start to change the consistency and even liquefy what’s being processed. The same can be true with grooming in that the quality of the snow can actually be adversely affected by going too fast. And fourth, regardless if using a single blade, multi-blade, or tiller to groom, too high of a ground speed results in a side-to-side rocking that produces a rough versus smooth finished trail. Irrespective of the type of groomer, the best quality trails, in terms of both smoothness and durability, result from grooming at speeds between 5 and 7 miles per hour (8 and 11 kilometers per hour).

After the processed snow passes through the last set of blades or the tiller, there should be an even blend of loose particles ready for compression.

Step 3 – Compression of the Processed Snow

The moist, loose snow created by the processing step must be “compressed” into an even covering of uniform density with a smooth surface. This process further de-aerates the snow and provides for a denser trail surface. As shown in Figure 1.8, this step is accomplished by a flat packing/compression pan at the rear of the drag.

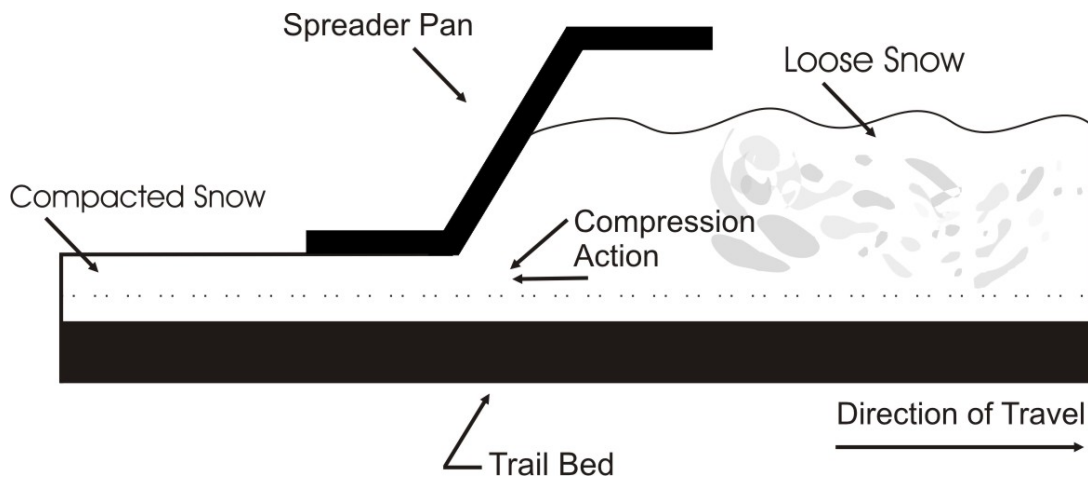

Figure 1.8 Step 3: Compression of the processed snow. The loose snow created by the cutting and churning action of the blades is distributed by the spreader pan, then compressed into a new layer of compacted snow on the trail bed.

On a multi-blade drag, the front of the pan is angled so loose snow that is contained by the side rails is captured and pulled under the spreader pan where it is then compressed by the weight of the moving drag. Since single blade drags typically do not have side rails, the snow must pass under the single blade of the unit and then be compressed by the drag's pan. If too much snow is carried in the single blade, it spills out the sides. This difference means that the multi-blade typically increases the finished snow depth/base of the trail with each pass, while the single blade increases trail depth only when there is an accumulation of new snow on the trail. While a tiller can apply down pressure when processing the snow, there is typically very little compression and generally is only from the unit's plastic comb.

Step 4 – Trail Set Up

Set up is simply allowing the snow that has been disturbed by cutting, processing, and compressing the proper time required to refreeze. Generally, the longer the set up time that is allowed, the more durable the trail will be and the longer the newly created smooth surface will last.

Once the drag or tiller has passed, the snow from the moguls should have been fully removed, processed, and redistributed as a new layer of denser, smoother “snow pavement.”

The last step in the grooming operation allows the moisture that was created during the processing step to refreeze. This binds the individual granules of tightly packed snow firmly together, creating a hard surface that will withstand passing traffic much better.

The length of time needed for a trail to set up correctly can vary from two to six or even more than ten hours, depending upon the temperature and moisture content of the snow. Trail set up can be similar to freezing a tray of ice cubes – after a short time there may be a crust but the cube isn't entirely solid and it generally takes a few hours for it to become fully firm. A snowmobile trail is no different. Therefore, it is vital that the trail remain as



Photo 1.12 A freshly groomed trail that requires set

undisturbed as possible during this set up period for firmer, better quality trails that will stand up longer to snowmobiling traffic.

Ideally a snowmobile trail would be closed during set up time, but that isn't practical. Consequently, the best time to groom is generally at night when traffic levels are typically lower and air temperatures are generally colder.

For the best set up, it is strongly recommended that grooming occur at night after snowmobile traffic subsides.

This also provides for the safer operation of both groomers and snowmobiles since it is easier to see oncoming lights and beacons. Most importantly, night grooming provides for more effective grooming since there is typically more time for the trail pavement to freeze solid before traffic resumes, maximizing the effectiveness of the area's grooming dollars.

It is recommended that daytime grooming be done in areas only if there is little or no daytime snowmobile use on the trail being groomed. Other exceptions would include special circumstances such as when daylight would aid operator visibility for initial early season trail set up and establishment or for trail reestablishment of the trail after big storms, extremely heavy snowfalls, and/or significant wind events.



Photo 1.13 Try to groom at times when snowmobiles will not follow the groomer for best trail set up

CHAPTER QUIZ

1. Snowmobile trail grooming is:
 - a) the single largest expense of a snowmobile trail program
 - b) using mechanical equipment to produce a high density snow surface
 - c) very demanding work that requires your undivided attention at all times
 - d) all of the above

2. Moguls are:
 - a) similar to washboards on a gravel road
 - b) patterns of mounds and dips formed in the trail's snow surface perpendicular to the direction of a snowmobile's travel
 - c) fun to ride
 - d) undesirable to snowmobilers
 - e) a, b, and d above
 - f) all of the above

3. Moguls should be:
 - a) cut off at the top and filled in the bottom
 - b) completely cut away
 - c) enhanced with the front blade
 - d) all of the above

4. The four basic operations of trail grooming include removing the mogul, processing and compressing the snow, and set-up. True False

5. Snow must roll or churn to be processed with a grooming drag. True False

6. Trail set up can be similar to freezing a tray of ice cubes – after an hour you may have a crust on the surface of the ice cube but the center isn't frozen, so you have to wait a few more hours for the ice cubes or the trail to fully freeze solid. True False

7. It generally takes a couple of hours or more of being undisturbed for snow to bond and reach full strength. True False

8. The length of time needed for a trail to set-up correctly can vary from two to six or even more than ten hours, depending upon the temperature and moisture content of the snow. True False

Chapter Two: *GROOMING EQUIPMENT*

The purpose of this section is to give a general overview regarding the various types of equipment that are available for trail grooming in order to help operators understand the general characteristics of the equipment they are operating. For a more detailed understanding of specific trail grooming equipment, operators should consult with equipment manufacturers and refer to the manufacturer's equipment operator's manual.

As touched upon in Chapter One, the grooming tractor is generally a heavy-duty, two or four-tracked vehicle whose primary purpose is to provide the power to pull a grooming drag, power a tiller, or carry a compactor bar across the top of the snow. Some areas also use farm tractors, with or without track conversions, to pull a grooming drag. Other areas use a wide-track, utility snowmobile or a tracked ATV to pull a miniature grooming drag.

There are several companies that manufacture tracked vehicles specifically for snowmobile trail grooming. They include but are not necessarily limited to: Tucker Sno-Cat, Pisten Bully, Camoplast Industrial (formerly Bombardier), Centaur, Lamtrac, and VMC. Some areas also continue to use out-of-production models formerly produced by ASV and Thiokol/DMC/LMC. Additionally, track conversion kits for farm tractors are commercially available from Gilbert, Marcel, Sur Trac, Arrow Trac, and what seems to be a growing number of sources. The grooming tractor should be of sufficient size and power to handle the grooming implement(s) that will be used to groom the trails, without being heavier or wider than what is really needed for the area to help keep operating costs down.

The actual work of grooming the snow on the trail bed is performed by the drag that is towed behind the tractor or by the tiller. There are numerous trail grooming drags commercially available, including but not limited to, TSI Mogul Master, Trailmaster, Arrowhead, AFMI Trailmaker, Maxey, Sur Trac, Sno-Plane, Sno Boss, Trail Plane, Spooner Machine, Easy Pull, and LaCross. Additionally, there are numerous homemade grooming drags in use across the Snowbelt. Tillers are generally available to fit Bombardier/Camoplast, Pisten Bully, and Tucker Sno-Cat tractors. Compactor bars are commercially available from The Shop Industrial (TSI), Tucker Sno-Cat, Pisten Bully, and Bombardier/Camoplast.

Grooming Drags

From the discussion on Grooming Steps in Chapter One, it should be clear that a grooming drag plays a very key role in successful trail grooming. In fact, the drag can often be the most important piece of the grooming equation and typically has a greater impact upon proper trail grooming than the tractor used to pull the grooming drag. Grooming drags have progressed a long ways from the simple "bed springs" and "pipe drags" first used by snowmobile clubs in the 1960s and 1970s in early attempts to smooth trails. Most modern drags are technically advanced devices referred to as "multi-blade drags," as opposed to an older generation of "single blade drags."

Multi-Blade Drags

Regardless of the manufacturer or individual details of design, multi-blade drags have become the current standard for most grooming organizations that use drags. In fact, they are such an important part of the grooming tool box that many believe a good multi-blade drag is the single most important ingredient of a good trail grooming program. If an area doesn't have one, purchasing one could be the single best investment the grooming program can make. Because of the superiority of the multi-blade design, this section will go into great detail to explain its features and operation since full-featured, heavy-duty multi-blade drags must be properly operated to be effective.

As the name suggests, multi-blade drags use at least two or often three or more sets of cutting blades to fully remove moguls and perform the all-important snow processing operation (see Photo 2.1).

Figures 2.1 and 2.2 show the top and side views of a typical multi-blade drag. While design details may vary between manufacturers, the basic principles are illustrated well by this typical unit.



Photo 2.1 Typical multi-blade drag

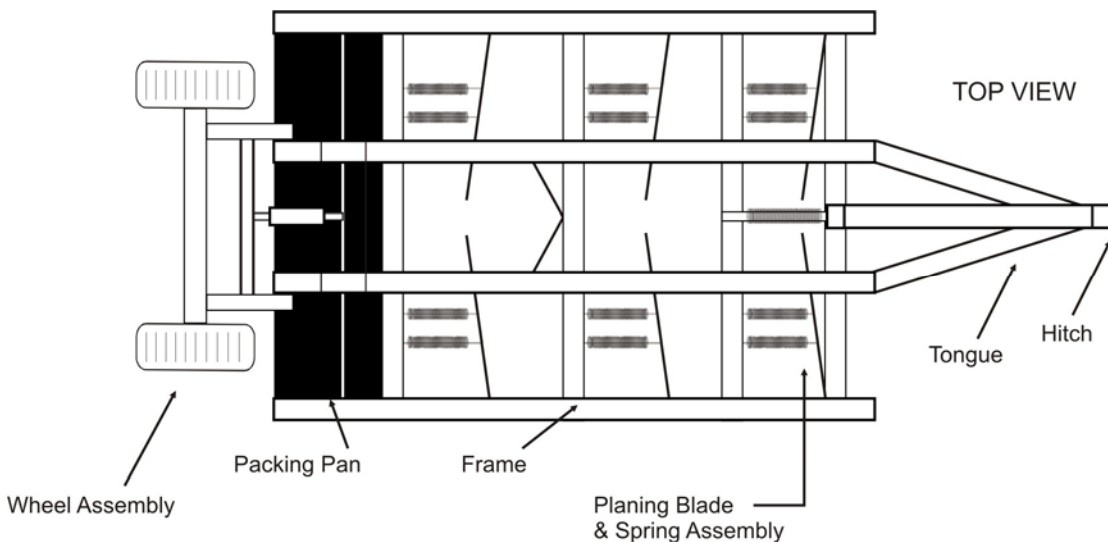

Figure 2.1 Typical multi-blade drag design – top view

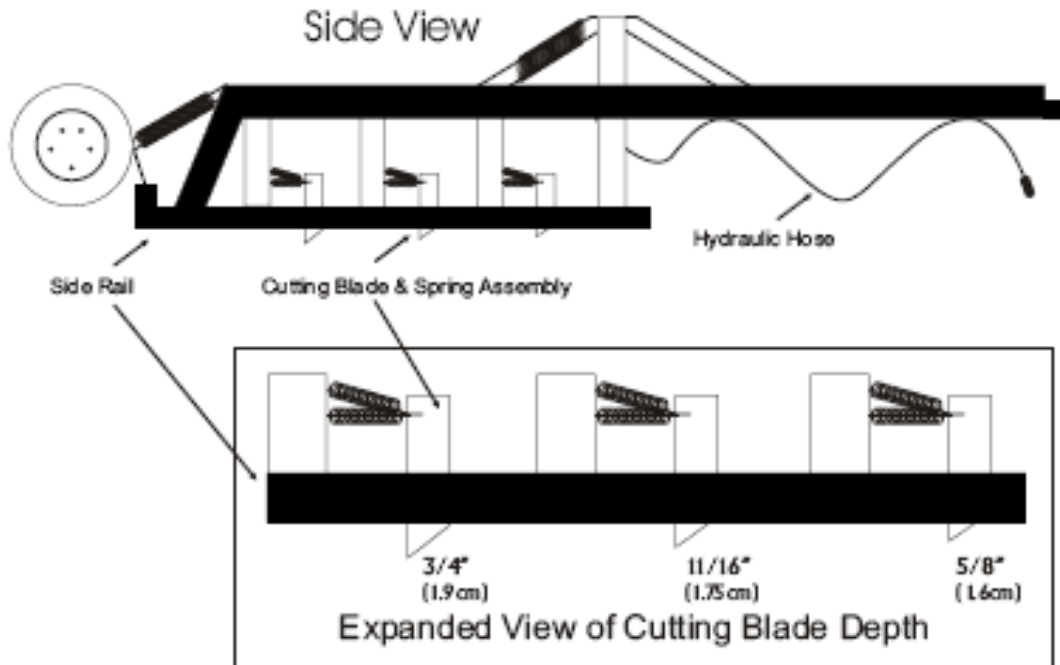

Figure 2.2 Typical multi-blade drag design: side view with expanded view of cutting blades

Drag Width

The width of the drag is dictated largely by the width of the trails that will be groomed and the width of the tracks on the tractor that will be pulling the drag. If the vehicle's track width is 8 feet (2.4 m), then the drag should generally also be at least 8 feet (2.4 m) wide. The width will also be dictated by the narrowest clearing width (between trees, gate posts, or bridge openings) on the overall trail system to be groomed. If there is a bridge that is only 8' 6" (2.6 m) wide, then the tractor and drag must be narrower than this even if the rest of the trail system is 10 feet (3 m) wide, unless the drag has wings that can be raised and lowered hydraulically like the one shown in Photo 2.2.



Photo 2.2 Drag with hydraulic wings

An eight to twelve feet (2.4 to 3.7 m) wide drag is commonly used by many areas since it will groom the entire trail width in a single pass. However on narrow trails with poor sight distance, it may be desirable to use a narrower drag width to provide snowmobile traffic a safe passing corridor. Trails that require a "doubling" (no option for grooming a

loop; it must be groomed to a dead end and then back over the same track) may also be a place where it can be desirable to use a narrower drag, since it requires two passes to complete the grooming run. In this situation, it can be effective to groom at a narrower width so the left track(s) of the tractor are in the center of the trail to help compact snow.

Drag Length

The length of the drag is important in that, the longer the unit is, the less tendency there is for it to follow the contour of the trail since it bridges from high spot to high spot, filling depressions as it goes, which leaves a smoother trail. This is important and one of the primary benefits a drag can have over a tiller. However, there are constraints to the overall length of a drag in terms of the ability to negotiate tight turns.

Generally, the heavier the drag is (without it being so heavy it is not efficient to pull), the better it is able to cut through moguls and compress loose snow after it has been processed by the cutting blades. However, the demands on the grooming tractor increase substantially as width, length, or weight of the drag increases that may make it too heavy for the tractor to pull. Be certain the tractor isn't overburdened with too large of a drag.

Typical Features of a Multi-Blade Drag

The following are brief descriptions of the typical features of a multi-blade drag:

Frame

The frame is typically fabricated from welded steel tubing and painted to inhibit rusting. The frame supplies a rigid foundation onto which the various components are attached and should not bend or twist significantly when stressed by the drag working. If the frame becomes bent or twisted, it can result in the drag cutting or compacting unevenly. Therefore, it is important that the drag's frame be regularly checked and maintained.

The frame is the major contributor to the weight of the overall unit which is an important design criterion. See examples of typical multi-blade drag frames in Photo 2.3.



Photo 2.3 Typical multi-blade frames and blade configurations

Side Rails

The outside edges of the frame form the skid surfaces upon which the drag slides and are referred to as the side rails. Side rails are important in that they keep the snow that is being processed contained within the inside of the drag frame. A major difference between multi and single blade drags is that single blade drags do not have side rails.



Photo 2.4 Side rail on a multi-blade drag helps keep snow contained within the drag.

Spring Tripping Blades

As the blades cut off moguls, they can often hit rocks, stumps, or other fixed objects buried in the snow. While not all drags have spring tripping blades (rather they are mounted solid so they do not “trip” when hitting a buried solid object), it is highly desirable that each of the individual cutting blades is spring loaded (see Photo 2.5), so they can trip out of the way if they hit a buried object. This can help prevent damage to the drag, tractor, and the operator.



Photo 2.5 Spring tripping blades



Photo 2.6 Spring shank blades

The cutting blades in some drags are mounted on spring shanks, similar to what are used on agricultural field cultivators and diggers (see Photo 2.6).

Cutting Blades

It is desirable for the cutting blades to be slightly beveled so they cut into the mogul versus being mounted straight up and down where the blade would simply skim over the top of moguls (see Photo 2.7). They are typically mounted in a “stepped” manner where the front row is 5/8” (1.6 cm) below the side rail and the rear row is up to 3/4” (1.9 cm) below the side rail. This provides more cutting depth as the frame is lowered. Also note that blades are typically mounted in an angled manner so they transfer snow from the outside of the trail to the center of the trail where wear is usually the greatest from snowmobile traffic.



Photo 2.7 Beveled cutting blades



Photo 2.8 Serrated cutting blades

Some drags also use serrated blades (see Photo 2.8) in the front row(s) which assist in cutting hard or icy trails.

Tongue

The tongue on many drags is hinged so it can move up and down at the drag frame, but not from side to side (see Photo 2.9). The up and down movement is controlled by a hydraulic cylinder operated from the tractor’s cab allowing for simultaneous, continuous control of blade cutting depth on multi-blade drags. The tongue may attach to the tractor with either a pintle hitch or a 5th wheel type of hitch. Other drags, particularly those used behind farm tractors, are steered hydraulically by means of a rigid hitch (see Photo 2.10).



Photo 2.9 Pivoting tongue

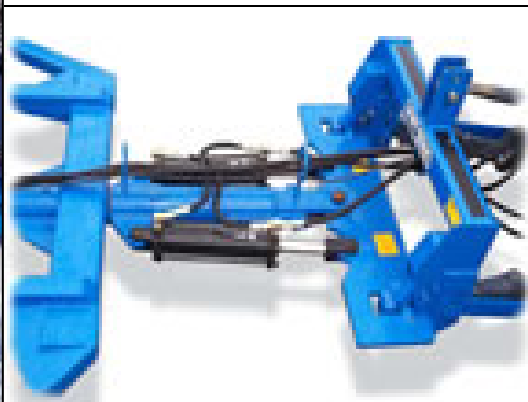

Photo 2.10 Rigid steer hitch

Compactor Pan

The compactor pan should provide for full width smoothing that leaves an evenly finished trail surface free of holes or divots. The front of the pan is angled forward to catch and spread the processed snow evenly across and under the pan (see Photo 2.11). The rear of the pan has a high radiused lip that aids in “ramping” the drag up onto the snow when backing up in soft snow without the aid of the wheels (see Photo 2.12).



Photo 2.11 Angled front of pan



Photo 2.12 Radius lip on rear of pan

The bottom of the compactor pan on a multi-blade drag is typically flat steel with wear bars or runners positioned at the two outside edges. Two to three additional replaceable wear bars are often evenly spaced across the center of the underside to help protect the pan surface. Some pans may also be surfaced with either a plastic comb material or sheets of corrugated steel. However, flat steel or corrugated steel is better than plastic for a pan’s bottom since they produce friction which is so important to the trail’s set up.

Skegs

Replaceable hardened steel skegs (runners) are normally mounted on the bottom of the compactor pan. These skegs reduce side hill slippage of the drag and also help prevent premature wear of the compactor pan. They are especially important to “drag steer” groomer configurations whereby the drag acts as the steering rudder for the entire grooming unit. Photo 2.13 shows the telltale marks from packer pan skegs.



Photo 2.13 Skeg marks on a freshly groomed trail

Vibrating Pans

Vibrating pans are a relatively new feature on multi-blade drags. They utilize a flow control valve and return system to hydraulically “vibrate” the rear pan in an effort to increase compression and aid trail set up. The hydraulic vibrator is mounted so as to isolate the vibration downward into the trail surface and away from the drag itself. They are most commonly used with agricultural tractors since their hydraulic systems more readily accommodate the operational needs of vibrating pans (see Photo 2.14).

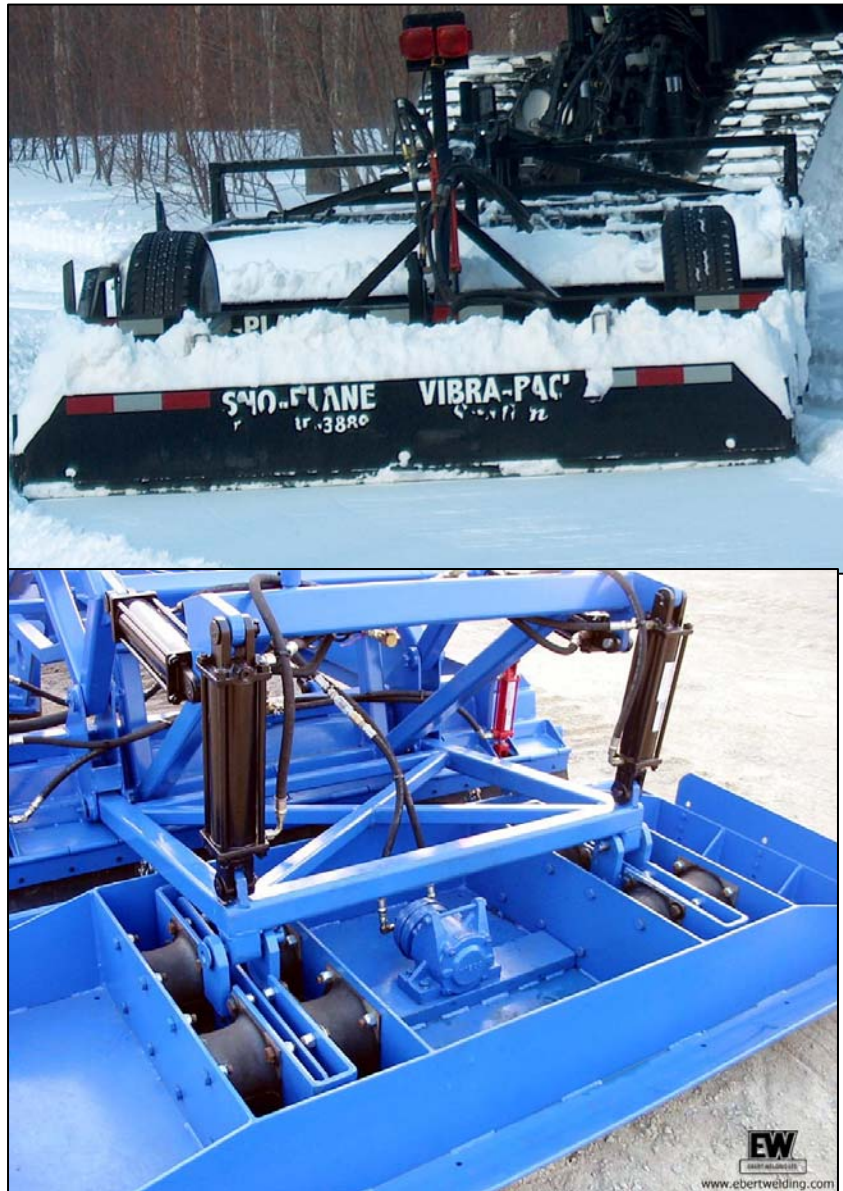

Photo 2.14 Typical vibrating rear pans

Wheel Assembly

The wheel assembly is a set of wheels, mounted either at the rear of the drag or within the frame assembly (see Photo 2.15), that can be raised and lowered by hydraulic controls from the tractor's cab. During normal grooming operations, the wheels are raised so they are out of the way. When crossing roads or railroad tracks, the wheels are lowered so the drag is picked up off the ground. The wheels are also helpful when backing up the drag.



Photo 2.15 Typical wheel assemblies

Some drags use a rear drum roller rather than wheels. The drum is typically operated like wheels in that it can be hydraulically raised and lowered (see Photo 2.16). It also can be used to aid trail compression and compaction.



Photo 2.16 Typical rear drum roller assembly

Quick Release Features

The drag may encounter immovable objects such as stumps or rocks that could damage it, the tractor, or the operator. Consequently, a shear bolt is generally used in the hitch that will break away before major damage occurs (see Photo 2.17 – to the right of the pintle). Quick-release couplings in the hydraulic hoses can also help ensure that the hydraulic system is not torn out in the event the shear pin releases the drag from the tractor.



Photo 2.17 Quick-release couplings and shear pin in tongue of pintle hitch

Single Blade Drags



Photo 2.18 Typical single blade drag

Many earlier drag designs, which are still used in some areas, incorporated a single, full-width cutting blade with the idea that it would carry snow and allow it to drop into depressions. Some designs also incorporated a rolling drum in front of the rear compaction pan. This type of drag can work well in areas with frequent, deep snowfall where grooming requires more continuous work to build new base because of frequent snowfall. However, in areas with heavy moguls, the single blade drag can be less effective due to its limitations for fully cutting and processing moguls. It is important that the tractor be equipped with a front blade to help process moguls in this situation.

Other than number and configuration of blades, the components of a single blade drag are very similar to that of a multi-blade drag. The operation is different than a multi-blade in that the height of the cutting blade is regulated by a hydraulic cylinder versus by the hitch. Additionally, since this type of drag does not have side rails to keep snow contained within the drag, snow can be easily wasted out the sides if the operator attempts to cut and carry too much snow with the single cutting blade.



Photo 2.19 Typical single cutting blade

Tillers

A tiller is mounted on the rear of a grooming tractor and is driven hydrostatically (see Photo 2.20). A tiller typically requires deep snow conditions and is used to break up compacted snow surface, to reduce snow and ice chunks, and to mix old and new snow.



Photo 2.20 Typical rear-mounted tiller

The tiller itself is similar to a garden roto-tiller and consists of a rotating shaft (cutter bar), which has multiple tines that are typically three to five inches (7.6 to 12.7 cm) in length that condition the snow when operated at a high RPM, and a plastic comb or “snow finisher” (see Photo 2.21). The tractor’s horsepower must be sufficiently large to operate the tiller.



Photo 2.21 View of the underside of a tiller

Benefits of a tractor equipped with a tiller include the extreme portability, ease of backing, ease of turning around, and ease of plowing drifts. Additionally, the unit can be easily stored and easily hauled on a truck or trailer.

A tiller can work well in moist snow, but if there is dry powder snow, it can sometimes be hard to get a good trail since the snow/trail doesn’t stay together. Therefore, it can be important for there to be good moisture in the snow to get good results and “snow pavement” that lasts.

If the trail is heavily moguled, multiple passes may be required since a tiller can only process to a maximum depth that is equal to the length of its tines (if it has 3 inch {7.6 cm} tines, then that is the maximum processing depth; if it has 5 inch {12.7 cm} tines, it can process to a maximum depth of 5 inches {12.7 cm}, etc.). In such cases, a good front blade on the tractor, and an operator who can cut moguls with the front blade, is required to feed enough snow to the tiller for processing and ultimately creating a smooth trail.

It is easy to build a smooth trail with a tiller, but not necessarily a level trail since the unit will bob up and down mirroring what the tracks of the tractor do. It can sometimes also weave side to side. For this reason, they produce better results on an undulating trail with frequent turns and ups and downs versus on a trail with long straightaway sections.

It is recommended that areas also have a drag to supplement trail grooming with a tiller, since it is rare that season-long grooming conditions (weather, snowfall, moisture, and traffic) are consistently favorable for grooming solely with a tiller.



Photo 2.22 Flex tiller set in a rigid (straight) position with lockout device shown below.

Flex tillers pivot (or flex) in the center and are typically used on downhill ski hills to create terrain features. Some manufacturers provide a lockout device whereby a flex tiller can be locked in a rigid/straight position which is required to groom a flat snowmobile trail surface.



Photo 2.23 Flex tiller lockout device

Compactor Bars



Photo 2.24 Typical compactor bars

A compactor bar, also commonly referred to as a “packer bar,” is a very simple, lightweight implement, short in length and attached to the rear of a tractor, which can be hydraulically lifted completely off the snow to allow the tracked vehicle to easily back up and/or turn quickly in tight spaces. Some models also have hydraulic down-pressure to help increase compaction.

It can be used to significantly reduce the time, effort, and cost of opening a snowmobile trail at the beginning of a grooming season by compacting snow on the trail to set up a firm base for future grooming with a drag. In swampy areas, it can facilitate compaction that helps drive the frost into the ground and helps freeze the swampy ground faster. The use of a packer bar generally saves wear and tear on a drag during early season trail set up and also provides for increased tractor maneuverability.

A compactor bar can also be used after exceptionally heavy snowfalls during the season or in areas of extreme drifting when a drag can be too much for the tractor to handle effectively. Some packer bars are designed so they can be mounted on the tractor while a drag is simultaneously hooked to the tractor’s pintle hook. With such a configuration, operators can groom with the drag up to a point on the trail where heavy drifting has occurred, unhook the drag, and continue through the area using just the vehicle’s front blade and the packer bar to establish an initial trail base. They can then return to the drag, reconnect it to the tractor, and proceed onward while “finishing” the trail with the drag.

Some areas “track pack” a trail route, with just the tractor and no drag, after a heavy snowfall or at the beginning of the season when there is deep snow and no established trail route. It can also be beneficial to track pack early in the season when there is low snowfall since the “crimping” effect of the tracks can help stabilize the snowpack. The use of a compactor bar, particularly when there is deep snow, can greatly increase the effectiveness and efficiency of grooming efforts when there is a need to track pack.

GROOMING TRACTORS

The name “Grooming Tractor” is used to refer to a broad range of tracked and semi-tracked vehicles used to pull grooming drags or to carry tillers and compactor bars. The term “tractor” is used generically to identify the purpose of the vehicle, which is to pull, power, or move a trail grooming implement, and should not be confused with farm tractor conversions that are sometimes also used as grooming tractors. Some areas also refer to grooming tractors as “prime movers.”

Samples of typical grooming tractors are shown below for the purpose of introduction:



Photo 2.25 Typical grooming tractors

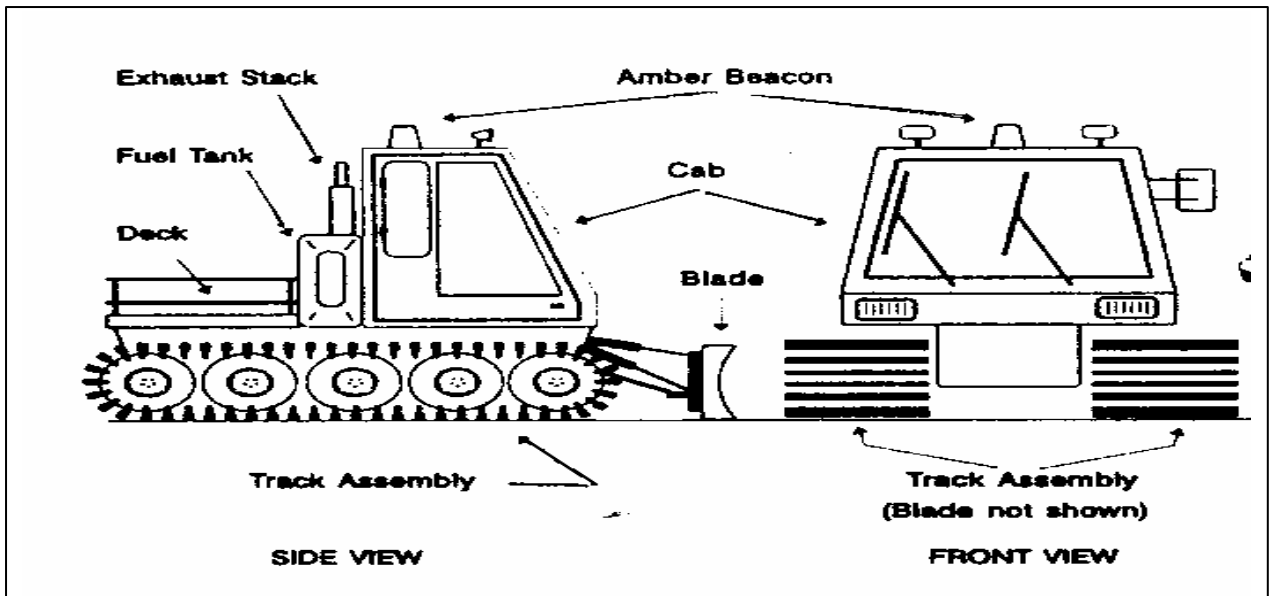

Figure 2.3 Typical components of a grooming tractor

Figure 2.3 shows the side and front views of a typical 2-track grooming tractor. While design details will vary between 2-track and 4-track vehicles, as well as between manufacturers, the basic components of a grooming tractor are illustrated well by this typical unit.

Grooming Tractor Components

Tracks

The tracks on a tractor provide “flotation” that help the vehicle stay on or near the surface of (versus sinking into) the snow (see Ground Pressure, page 40) while providing sufficient traction to pull a heavy grooming drag or to carry an implement such as a tiller.

Historically, most grooming tractor tracks were cleated with a straight steel or aluminum bar (see Photo 2.26 on the next page). Such a track requires that the vehicle be operated in deep snow to avoid damage to the tracks. Oftentimes, ice picks or grousers are added to these tracks to help prevent side slippage and spinout on hills.

Many contemporary grooming tractors are equipped with all-rubber tracks, which allow the vehicles to be operated in all types of terrain without damage to the tracks. Some rubber tracks have a straight bar type pattern, while others have a Z-type pattern to help prevent side slippage and to increase traction (see Photo 2.27 on the next page). Machines equipped with rubber tracks can run on dry pavement, dirt roads, in mud, in water, and in deep powder snow which makes them much more versatile. While they initially may cost more, they typically have a smoother ride which provides additional operator comfort, less operator fatigue, and less maintenance costs and vehicle damage caused by vibration.



Photo 2.26 Example of steel-cleated track



Photo 2.27 Example of rubber track

Steering

Steering is accomplished on some 2-track models by individual braking of the tracks, similar to how a bulldozer is turned. On other 2-track models, steering is accomplished by individually controlling track speed using a hydrostatic drive system. Most 4-track models articulate, so one set of tracks turn inward while the other set turns outward. Farm tractor conversions typically utilize the drag as a steering rudder.

Engine

Motor power for the grooming tractor is provided by a large diesel or gasoline industrial engine. The location of the engine is important when determining the vehicle's center of gravity since it is typically heavy (see Center of Gravity, page 41).

Tractor Cab

The grooming tractor's cab provides a protected environment for the operator. Many also have additional seating for a passenger that is useful for training or for a relief operator on long runs. Most grooming tractors have complex instruments for operating the tractor, as well as hydraulic controls that operate the grooming drag, front blade, tiller, and other attachments. It is important that operators familiarize themselves with all controls to ensure safe and effective operation of the equipment. Vehicles that have an up-front cab style provide better forward visibility for the operator, particularly when using a front mounted blade.



Photo 2.28 Typical controls in a tractor's cab

Front Blade

Many tractors are equipped with a front blade which is a useful accessory to knock down snow banks or drifts and to fill in creek crossings or large depressions in the trail bed with snow. A blade is also useful to keep road crossings and driveways clear of snow deposited by grooming, so as to not create hazards for motorists or obstructions to adjacent landowners' property. A front blade is also essential when establishing trails along hillsides in deep snow areas or when using a tiller.



One common misconception about the front blade on grooming tractors is that they can be used as a bulldozer. This is not true and, if used as such, can result in major breakdowns and repairs. Front blades on grooming tractors are typically not as strong as the blade on a bulldozer, so they should never be used as such for pushing large rocks, stumps, or trees.

Photo 2.29 Typical front blade at work

Cargo Deck

Most grooming tractors have a rear cargo deck to carry utility loads such as tools, chain saws, spare fuel, trail signs, etc. The operator must be aware that overloading the cargo area on the tractor can impact the vehicle's weight, flotation, and center of gravity, so caution should always be used to not improperly load the vehicle.



Photo 2.30 Typical cargo deck used to carry tools, spare signs, and spare fuel

Important Characteristics of Grooming Tractors

There are several characteristics that are important to understanding the capabilities and the proper operation of grooming tractors. These characteristics include:

Ground Pressure

A vehicle that is designed to work in snow must stay on or near the surface rather than sink in and plow through the snow. This is accomplished by spreading the weight of the vehicle out over the tracks, much as a snowshoer's weight is distributed by the snowshoes.

The technical measure of the vehicle's ability to distribute weight is called ground pressure. Ground pressure is calculated by dividing the overall weight of the vehicle by the total area of the track which remains in constant contact with the snow and is most often expressed in pounds per square inch (psi) or kilogram-force per square centimeter (ksc).

Typical ground pressures for moderate-light to heavy grooming tractors range from 0.8 psi (0.056 ksc) to 1.2 psi (0.084 ksc). It is very important that tractor ground pressure not exceed these limits. If ground pressure is too high, the vehicle will sink into snow rather than stay on top. If ground pressure is too low, the unit may not have sufficient traction to pull a drag up hills or through deep, heavy snow.

Overall Weight

Within reasonable limits, the overall weight of the tractor can be compensated for by matching it with the appropriate track area. However, overall weight is a factor in terms of existing bridge loading limits and crossing frozen bodies of water. Because grooming vehicles are typically very heavy, it is recommended that they never be operated on frozen bodies of water without special planning, testing, and training since doing so could lead to equipment damage, serious personal injury, or death.

Engine Horsepower and Torque

Regardless of whether a diesel or gasoline engine is installed in a particular tractor, the key measurements of its capability are its horsepower and torque. Always use the same measurements when comparing horsepower, since there are gross, net, and power-take-off (PTO) measurements. Gross brake horsepower is a good basic unit for comparing the relative power of engines.

Engine torque is an overlooked rating that is very important for all grooming tractors. Torque relates to the ability of the tractor to get a heavy drag moving. The high static loads of modern multi-blade drags require a high degree of engine torque to get a drag moving from a dead stop.

Center of Gravity

A vehicle's center of gravity is a point around which its weight is evenly balanced. Figure 2.4 is an example of the center of gravity for a typical 2-track grooming tractor.

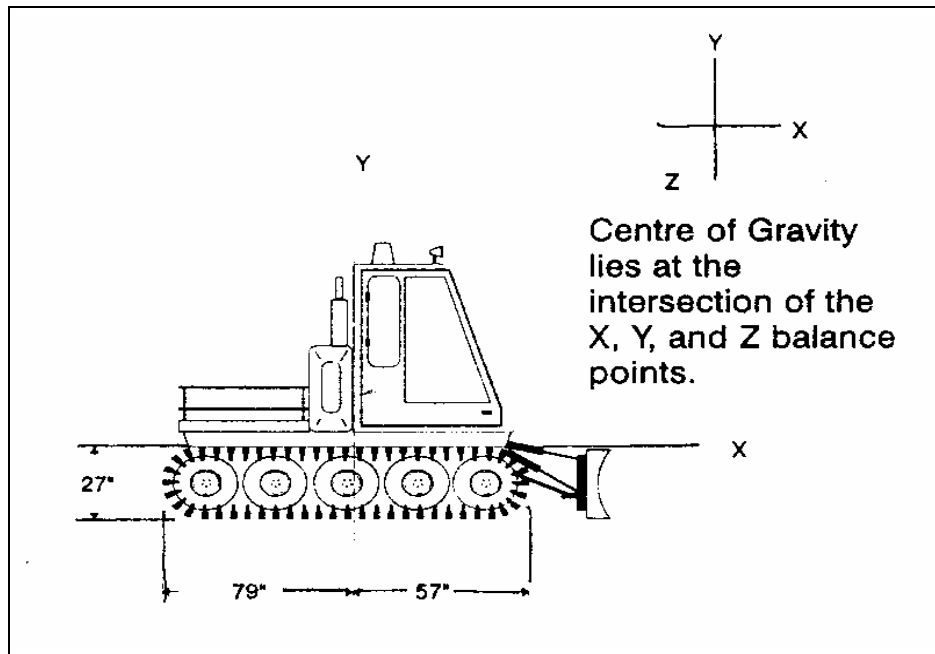

Figure 2.4 Center of gravity for a typical 2-track grooming tractor

A vehicle's center of gravity is significant any time it must operate on a non-level surface such as when climbing or descending steep grades or when side hilling. In terms of stability, the lower to the ground the unit's center of gravity is the more stable it will be on non-level surfaces. Operators should keep this factor in mind to avoid getting into unsafe situations.

Tractive Effort and Coefficient of Friction

Tractive effort is defined as the amount of torque that can be applied to a track before the track loses traction and spins without moving the vehicle forward.

The coefficient of friction between the track and the ground or snow is the limiting factor of when the tracks will lose traction. Coefficient of friction is determined by the overall vehicle weight, the amount of track on the ground, the cross-link design of the track, and the weight distribution along the length of track that is in contact with the surface. The ideal weight distribution on the tracks is having the balance point, from front to rear of the vehicle, at or near the center point of the length of track, as shown in Figure 2.4 above.

When a track breaks traction it is actually shearing the snow through the force that the cross-links are placing on it. Fresh, unpacked snow shears much more readily than hard packed snow. When a vehicle breaks traction, spins out, and gets stuck, it happens because the force required to shear the snow is less than the force required to pull the load. The load is made up of both the drag and the tractor.

Snowmobiles and ATVs as Grooming Tractors

Some areas use either a wide-track/utility model snowmobile or a tracked ATV to groom their snowmobile trails. In these applications, the snowmobile or ATV is typically used to pull a small grooming drag (usually only about 4 feet {1.2 meters} wide) when there are limitations with trail widths that prevent a large tractor from grooming the trails. A snowmobile or ATV may also be used because of funding limitations in the area that preclude the capital expenditures required for larger equipment. While there are limitations as to what can be successfully groomed with a snowmobile or ATV, these units can serve a valuable purpose. One key to success is frequent grooming repetitions to compensate for the cutting and compression limitations that small drags typically have.



Photo 2.31 Typical snowmobile powered grooming unit

The grooming drag is typically controlled by an electric-hydraulic switch operated from the seat of the snowmobile or ATV. This allows the operator to make drag adjustments just the same as if the operator were in a full-sized tractor cab.

Because the operator is out in the elements, it is important that extra safety precautions are taken for operator safety and that the operator has adequate dry clothing along. It is also important that a tow rope and shovel are carried on the snowmobile or ATV since it is easy to get these units stuck. A spare drive belt for the snowmobile should also be carried since pulling the grooming load can be hard on the snowmobile's clutch and drive belt. All other grooming and safety principles apply, just on a smaller scale.



Photo 2.32 Typical ATV powered unit

CHAPTER QUIZ

1. Grooming implements include:
 - a) drags and planers
 - b) tractors
 - c) tillers and compactor bars
 - d) a and c above
 - e) a, b, and c above

2. The purpose of the front blade on a grooming tractor is to clear rocks, stumps, and downed trees from the trail to make it safe. True False

3. The primary purpose of a grooming tractor is to provide the power to pull a grooming implement like a drag, power a tiller, or to carry a compactor bar across the top of the snow. True False

4. The tractor is the most important piece of the grooming equation and has a greater impact on proper trail grooming than does a drag or tiller used behind the tractor. True False

5. If you were to use only one grooming implement to build a trail that is both smooth and level, it would in most cases be a:
 - a) tiller
 - b) multi-blade drag
 - c) compactor bar
 - d) single blade drag
 - e) front blade

6. A very simple, lightweight implement that is very maneuverable and useful for initial trail set-up early in the season or deep snow events is a:
 - a) tiller
 - b) multi-blade drag
 - c) compactor bar
 - d) single blade drag
 - e) front blade

7. Overloading the cargo area on a grooming tractor can impact the vehicle's weight, flotation, and center of gravity. True False

8. Too low of a ground pressure can cause a grooming tractor to sink into snow rather than stay on top of the snow. True False

9. The frame of a drag must be rigid and square to prevent it from cutting or compacting unevenly. True False

10. The cutting blades on a multi-blade drag are typically mounted in a “stepped” position, downward from front to rear. True False
11. The maximum width of a grooming implement like a drag or tiller is:
- a) dictated by the maximum width of the trails to be groomed
 - b) dictated by the width and power of the tractor
 - c) not important
 - d) generally narrower than the tractor
 - e) a and b above
 - f) none of the above
12. The tracks on a grooming tractor must be large enough to keep it on or near the surface of snow. True False
13. A tractor with a high center of gravity will be stable and safe to operate on steep hillsides. True False
14. When a vehicle breaks traction, spins out, and gets stuck, it happens because the force required to shear the snow is less than the force required to pull the load. True False
15. The overall weight of a grooming tractor is:
- a) unimportant
 - b) can be compensated for by track area
 - c) can cause problems when crossing bridges and ice
 - d) b and c above
 - e) none of the above

Chapter Three:

MANAGING GROOMING OPERATIONS, EQUIPMENT, and SAFETY

Grooming operations are typically the largest part of an entity's budget in terms of the capital costs to purchase equipment, the ongoing operational costs of grooming, and the costs associated with repair and maintenance.

While there is no perfect way to manage grooming operations, this section provides basic guidelines for the management of trail grooming equipment and operations. What equipment to purchase, who will operate it, how will it be scheduled, where it will be stored, and how it will be maintained are all critically important decisions that must be made to properly manage grooming equipment. While some of these decisions are far-removed from the grooming equipment operator, a basic understanding of the "big picture" helps facilitate a better, more effective grooming operation.

The Grooming Program Manager

Good quality grooming doesn't just happen by chance and will not be assured simply because new, fancy, or expensive equipment has been acquired for the grooming program. Successful grooming programs require a great deal of planning and management. And good equipment isn't a substitute for poor operators.

Regardless of the size of a grooming operation, it is recommended that there be a qualified manager in charge of the day-to-day grooming operation who understands heavy equipment operation and maintenance, trail grooming principles and practices, and snow mechanics. The ability to work with a diverse group of volunteers or employees, while balancing leadership and authority, is also a definite plus for this position.

The title of "grooming program manager" is important since it clearly defines the role of the individual filling the position. "Grooming" clearly indicates the focus of the job. "Program" suggests that grooming is a planned and coordinated activity which cannot be left to chance. "Manager" defines the role as coordinating and directing all aspects of the overall grooming program.

Particularly with volunteer club grooming operations, if a suitable candidate is not available within the existing organization, one needs to be recruited or hired. Typically, qualified heavy equipment managers who often are not busy in the winter months can be good candidates to recruit for this responsibility. An individual within the volunteer organization simply "taking" this job "because no one else will" is a recipe for disaster and should be avoided.

Establishing Grooming Priorities

Snowmobilers would like to see every trail groomed tabletop smooth every day of the week. However grooming resources, in terms of available equipment and existing budget, are usually limited, so choices have to be made as to what the grooming priorities are. Grooming schedules should be developed that divide trail systems into manageable sections based upon what the budget and volunteer or labor resources will allow. Once priorities that consider traffic patterns have been determined for each trail section, a weekly schedule can be created by assigning grooming equipment and operators (Refer to the Appendix for a sample Weekly Grooming Schedule). Keep in mind that, while schedules are great for planning how to use resources, weather and changes in traffic patterns can upset the best laid plans. The Grooming Manager must stay engaged and flexible to ensure grooming is directed toward the highest priorities if conditions change.

Factors to Consider

A number of factors should be considered when determining priorities and schedules:

- Where is the “base of operations” for the grooming program located? Is it central to the trail system or is it located at one end of it? How many miles/kilometers of trail must be groomed?
- What is the normal use pattern on the trail system? Is the snowmobile traffic normally heavy only on weekends or is traffic heavy every day of the week? Is there typically heavy night riding or are snowmobilers generally off the trail by dark? How early in the morning do riders normally get on the trail?
- Are there lodges, motels, hotels, or other businesses located on the trail that contribute large numbers of riders on a daily or regular basis? Are there attractions on the trail system that draw more traffic than other parts of the trail system? Are there trailheads or parking areas that regularly draw more use than others on the trail system?
- How many groomers are available for the trail system? If there are two or more available in the area, can they be staged in different locations or must they all operate from the same base? How many miles/kilometers of trail can each unit effectively groom each day/night when considering the set up time required to avoid heavy snowmobile traffic, average grooming speed, and normal weather patterns and temperatures?
- How many weeks will there be enough snow and traffic to justify the expense of grooming operations in the area? Should the trails receive more grooming during some weeks (middle of the season or around holidays, for instance) than others?
- What is the cost to groom a mile/kilometer of trail one time (fuel, maintenance, repairs, equipment depreciation, and labor as applicable)? How many dollars are available to fund these costs for the season? Will all labor be “paid” labor or will there be volunteer labor to supplement operating costs? If there is volunteer labor, how many hours per week will be dependably and consistently available? How many total miles/kilometers of grooming effort will this fund each week?

The answers to these questions all contribute to establishing priorities and setting grooming schedules that will be as effective as possible to address grooming needs.

If areas have traffic levels that are generally low, with little night riding and low weekday traffic, there is typically much flexibility as to when grooming efforts can be effective and few grooming repetitions per week will generally be required to have good trails.

If traffic levels are high everyday of the week, areas must look closely at scheduling factors to be as effective as possible with grooming expenditures. It is likely that 3 to 5 or even 7 repetitions per week may be needed to have good trails. And multiple groomers, staged at multiple locations, may be required since 40 to 60 miles (65 to 95 kilometers) is about the maximum a single unit can effectively groom per night without getting into times/traffic/temperatures that may not be productive for grooming. While some high traffic areas choose to groom mid-day to keep moguls from getting too deep, such efforts should be secondary to regular grooming at night (also), or when there is less traffic, to provide proper time for trail set up since it will generally not occur mid-day with traffic.

Operator Selection and Training

For many of the same reasons that a skilled Grooming Program Manager needs to coordinate a grooming program, skilled grooming equipment operators need to be carefully selected and trained. Grooming Equipment Operators should be selected based upon their ability to operate heavy equipment and then be thoroughly instructed and tested on the operating features of grooming equipment, grooming principles and procedures, maintenance schedules, and safe operating procedures.

Operators should be knowledgeable of grooming practices and should have a fairly high degree of mechanical aptitude since on-the-trail repairs and adjustments are inevitable, even with the best and newest equipment.

An operator training checklist should be used to help deliver effective and consistent operator training. Training topics should be customized by the Grooming Manager to cover local issues, but should also cover general items such as grooming practices, vehicle characteristics, and vehicle operation. Following this process can help ensure that operator training is thorough and complete (Refer to the Appendix for a sample training checklist).



Photo 3.1 Operator training is important and should include hands-on in-shop maintenance instruction.

Operator Safety

Ensuring the safety of equipment operators must be the first priority of the grooming program. While the specific circumstances of every area's operation are different, there are a number of common safety practices that should be followed universally. The following is a list of common operator safety considerations. Local grooming entities are encouraged to add additional measures that fit their needs and local circumstances.

Always Wear Seat Belts

Operators and passengers should wear seat belts at all times since sudden stops caused by the grooming equipment hitting fixed objects, such as rocks and stumps, are not uncommon and can easily launch the operator or passenger headfirst into the windshield or dashboard. Always proceed cautiously when operating grooming equipment since abrupt, dangerous stops can result in serious injuries.

Be Visible to Snowmobilers

Ensure that the vehicle is highly visible in the daytime, as well as at night, by using reflective surfaces on the equipment and by always operating with cab marker lights, front and rear headlights, and an amber beacon turned "ON" at all times (day or night). Also operate a communicator radio beacon in the tractor at all times.

Be Prepared for Trouble

Grooming equipment *will* malfunction, break, and get stuck. Contemplate all potential problems and provide procedures, tools, spare parts, and supplies to deal with them. Provide first aid kits and training for operators. Remember that they may also encounter members of the public who need help. A GPS unit is valuable to provide guidance during whiteouts and to provide rescue coordinates. Operators should be prepared to put winter survival techniques into effect in the event they become disabled in a remote area and must stay overnight. An avalanche beacon and probe (to assist with a rescue) should also be considered if operating in mountainous areas.

Essential tools that should always be carried include: axe, chainsaw, jack, snow shovel, chain/tow strap, rope, and flashlight.

A list of standard safety/emergency equipment should be carried in the groomer. Items to consider include:

First Aid Kit	Spare Batteries	Fire Extinguisher
Foil Blanket	Weatherproof Matches	Chains
Flares	Hydraulic Hoses/Fittings	Pry Bar
Spare Clothing	Tools	Paper
Towels	Snow Scraper	Plate for Jack
Hand Cleaner	Hi-Lift Jack	Tree Strap
Oil	Extra Fuel	Stakes
Sledge Hammer	Orange Spray Paint	Butane Torch/Heater

It is recommended that every grooming tractor carry a minimum of four 14-inch (36 cm), reflective, high visibility traffic cones. Use them to identify potential hazards such as a disabled groomer or winching cables, chains, or ropes temporarily strung across the trail.

Groomer operators should always be prepared by having a supply of high energy food, as well as a supply of drinking water, with in the tractor in the event they become stranded. Never leave home without packing a good sized lunch!

Avoid Grooming Across Ice

Some State or Provincial trail programs do not allow groomed trails to cross lakes or other major ice crossings. If it is necessary to groom across ice, procedures (how thick, how is it checked, monitored, etc.) must be established to ensure that ice quality is adequate in thickness and quality before crossing. Some manufacturers install escape hatches (sun roofs) in their units to facilitate emergency operator exit from the cab should the unit go through the ice.

Stay in Communication and Work the Plan

Modern FM radios and cellular or satellite telephones make it easier for operators to stay in frequent contact with their home base. Always file a “trip plan” before leaving on a grooming run. Agree upon a regular schedule of contact between the groomer operator and home base and the procedure that will be followed if contact is lost. Ensure that a plan is in place should contact be overdue or an actual emergency is reported, and then stick to the plan.



Carry Extra Signs for Replacement

A supply of extra trail signs, stakes, and fasteners should be carried on the grooming tractor to replace missing signs or stakes since the groomer operator is often the most familiar with where these signs should be along the trail. Replacing the missing signs, particularly safety and regulatory signs, helps ensure that the route will be safe for snowmobilers, as well as for the groomer the next time it must pass through that area.

Routine Preventive Maintenance

The importance of an effective preventive maintenance program to safety should not be underestimated. Well maintained equipment is far less likely to injure an operator or to strand an operator in a dangerous situation. Failure to perform preventive maintenance procedures should be treated as a safety violation rather than an operational oversight.

Check Equipment Prior to Departure

Thoroughly check the tractor over *prior* to departure on a grooming run. Check the fuel and fluid levels. Check for cracked or broken parts. Check the tracks. Check the hydraulic lines. Check the flashlight and be sure the tool and emergency kits are together. Be sure to have adequate clothing along in case the heater or tractor quit. **DO NOT** leave unless everything checks out okay and is in place.

Use Caution When Stopping or Parking on the Trail

Always use caution when stopping or parking on the trail, so the groomer does not become a hazard for approaching snowmobilers. There are essentially two types of stops, planned and unplanned.

Planned Stops: A “planned stop” is one made by a groomer operator when there is full control over when and where to stop.

Always use good judgment in where stops are made on the trail and be certain the groomer is well off the main traveled portion of the trail, if at all possible, when the machine is parked. Plan ahead and pull over in an area that minimizes risk to traffic on the trail. Pull completely off the trail on a straightaway, at an intersection, or in a parking lot whenever possible to prevent having to stop on the trail and potentially create a hazard.

It is good to develop areas on the trail system where planned stops and/or turnarounds can be made safely, and then keep these areas packed throughout the winter season.

An example of when it is beneficial to try to use a planned stop is when snowmobilers approach from the rear of the groomer on a narrow or winding trail. Signal for them to wait to pass the groomer until you’ve found a safe location to stop the groomer. Once the groomer has stopped and it is clear ahead, signal for them to go by.

Unplanned Full Stops: An unplanned full stop is one made by a groomer operator when there isn’t control over the location of the stop. This can include meeting snowmobiles on a very narrow trail, having snowmobilers stop the groomer to ask for information, encountering blow-downs or other situations requiring trail maintenance, mechanical failure of the groomer, encountering a disabled snowmobile, or encountering an accident on the trail. Operators must use their best judgment to size up the location of the unplanned stop. Is the site safe or unsafe to stop with the groomer?

If you believe the location has good visibility, that the expected time to get underway again will not be lengthy, and that it overall is safe to stop at the site, stop briefly to correct the problem, handle the situation, or give information, but do it as quickly as possible and then get underway again.

If you believe the site is unsafe due to the location and/or visibility, look for other options and if possible use extreme caution while proceeding to a safer location to stop.

General guidelines for unplanned stops include:

Snowmobiles Approaching the Groomer from the Front: When snowmobilers approach the groomer from the front on a narrow trail, move the groomer to the far right side of the trail as quickly as possible and stop. After checking to see that no traffic is coming from the opposite direction, signal to the snowmobilers to proceed past the groomer.

Informational Stop by Snowmobiler: Tell the snowmobiler that it is not a safe location to stop. Request that they follow the groomer down the trail to a safer location where you'll stop and answer their questions.

Repairs to the Trail or Removing Blow-Downs: If you anticipate the time needed to stop to remove debris or deadfall or to repair the trail will be relatively short, make sure all of warning lights remain on, and quickly make the necessary corrections to the trail, then get underway again. If the stop is anticipated to take a longer period of time, consider placing warning devices, like what are shown in Figure 3.1, on the trail to warn snowmobiles of the groomer's presence.



Photo 3.2 Stop only where there is good sight distance



Figure 3.1 Use warning devices like traffic cones, flares, crossed poles, or flagging to warn snowmobilers of parked groomers and on-trail hazards.



Mechanical Failure of Groomer or Stuck on the Trail: If the groomer becomes disabled or stuck on the trail and cannot be moved, take action quickly by placing warning devices in the front and rear of the groomer to warn approaching snowmobiles of the hazard. If the groomer needs to be left on the trail for an extended period of time, place additional warning signs or devices to mark the groomer's presence.



Photo 3.3 Place cones or other warning devices around and in advance of a groomer that has broken down on the trail and must remain there for an extended period.

Assistance to Disabled Snowmobiler: If you anticipate that there will be a need to be in the location for an extended period of time, park the groomer as far right on the trail as is safely possible and place warning devices in front and back of the groomer. If communications are available, call for assistance for the snowmobiler and get underway again as quickly as possible.

Crash Related Stop: If you come upon the site of any crash, presume that it is most likely an “Unsafe Site.” DO NOT proceed until the site is made safe!

First, park the groomer as far right on the trail as is safely possible and place warning devices on the trail to warn snowmobilers of the hazard. After securing the site, assess the situation to determine if there are any injuries and, if so, the type of injuries and the number of people injured.

If the accident is because a snowmobile collided with the groomer, do not move the equipment – just secure the scene and assess the needs.



Photo 3.4 Beware that collisions may be with the groomer!

As you assess the situation at the accident scene, determine if current resources at the site are sufficient to handle the emergency. If the answer is “Yes” – offer any assistance you can give and stay at the site until the trail has been cleared.

If the answer is “No” – the current resources at the site are not sufficient to handle the emergency, take control and:

- A. Call local dispatch or 911 if phone or radio service is available. If not, send someone for help.
- B. State the problem or situation.
- C. Give the number of injured, if any.
- D. Give the location, trail number, or trail name.
- E. If known, state the best way for rescue to arrive.
- F. Stay calm and do not talk too much.
- G. Don’t move the injured, but protect all victims at the scene and keep the injured warm.
- H. If there are bystanders, ask them to either close the trail or direct traffic until other help arrives.
- I. Update emergency personnel upon their arrival.
- J. **DOCUMENT, DOCUMENT, DOCUMENT!** After the scene has been turned over to emergency personnel, write down everything that you observed and that transpired while you were at the accident scene.



Common Operator Guidelines and Policies

For the benefit of the operator and/or grooming program, many areas have formal guidelines or policies related to operator safety, practices, or behavior that include:

No Alcohol or Drugs

Many areas have a Zero Tolerance policy regarding the use of alcohol or drugs when on duty. Other areas also specify a period of time prior to a grooming shift where alcohol cannot be consumed to prevent operators from showing up for their shift under the influence of or impaired by alcohol or drugs. Some areas go as far as to not allow groomer operators to run their shift if they have a hangover since the Grooming Managers believe this also constitutes an “impaired” and therefore unsafe situation. Zero Tolerance means there is no second chance – operators are terminated for their first infraction since the safety risks and liability associated with impaired groomer operators can be extremely significant.



Photo 3.5 The operators of this groomer were smoking marijuana and drove off the bridge.

No Smoking

Many areas prohibit smoking while in grooming equipment, in their shop, and in maintenance areas. Certainly, smoking must be prohibited around all refueling areas. Smoking bans are due to operator health and safety. Smoking in the cab of grooming tractors can also decrease the unit’s resale value.

Firearms

Many areas prohibit an operator from carrying a firearm in the grooming tractor as a safety as well as a liability issue. Additionally, many government agencies involved with trail grooming have policies that prohibit employees from hunting while on duty.

Passengers in Groomer

While some areas routinely groom with two people in the grooming tractor (a driver and an assistant), other areas prohibit the operator from carrying passengers not involved with the grooming operation. The most important aspect of whether or not to allow passengers is a safety issue. First, is the operator competent enough to not be distracted by a passenger? Second, the Manager should know beforehand that there is a passenger so, in the event of an emergency, rescuers know how many people they need to retrieve.

Communications

Communications are so important to the success of any grooming program that many areas have established formal communication policies and procedures. All are based on the need to communicate, communicate, and communicate some more! Operators must communicate the condition of equipment to other operators and the Manager. They must communicate the condition of the trails they have been over to relief operators and the Manager. They must communicate anything (weather, large groups, trail conditions, hazards, etc.) they even slightly suspect to be pertinent to the overall grooming program to the Manager. They must communicate to someone (dispatcher, family, or Manager) when they depart on a grooming run, their planned route, as well as their safe return. And when in doubt, they must feel safe to ASK, because there is no dumb question!

Grooming programs should invest in good communications equipment – whether cell phones, satellite phones, or two-way radios – to help ensure successful and effective communications within the program.

Preparing the Trail

Remove Bumps, Holes, and Debris Prior to Snowfall

Trail preparation prior to freeze-up and snowfall can be the single most important item to help provide a smooth and stable winter trail. The trail base should be made as smooth as practical since bumps and holes in the ground will also produce bumps in the trail after snowfall. Therefore, bumps and holes in the ground should be improved or removed prior to snowfall, with whatever equipment is practical and available, since removal after the ground is frozen or snow covered is much more difficult. Bumps located under the snow trail can reappear as bumps/moguls on heavily traveled trails almost immediately after grooming.



Photo 3.6 Trail maintenance prior to snowfall can help make trails smoother in the winter.

Brush, stumps, and debris should also be removed from the trail, as well as along the trail, in areas where it could be a hazard to traffic or block visibility. A wide, smooth, brush-free trail makes grooming easier. Keeping debris off the trail helps prevent hazards as well as premature thawing of the trail base since debris can attract heat that can accelerate thawing the snow around it. It is also good to set trail markers and signs that must be driven into the ground before the ground freezes.



Photo 3.7 It is easier to remove stumps, brush, and debris before snowfall accumulates.

Early Season Trail Preparation

The first snowfalls that are processed on the trail often create the base for the remainder of the winter. An early solid, smooth base of snow will help keep the trail smoother throughout the rest of the winter. Early winter snowfalls can contain more free water and can compact well. Therefore, vigorous smoothing and heavy compaction is often important for early snows. Newly fallen snow layers should ideally be cut to 6 inches (15 centimeters) or less before compacting to ensure full compaction throughout the layer. Thick layers of newly fallen snow typically do not compact well.

In areas prone to wetness, such as low swampy crossings, it is advantageous to keep the snow thickness to a minimum in the early part of the winter. This allows the underlying soil to freeze and become stable. This frozen layer of earth will also help to keep the trail solid later into the spring season. Since snow is an excellent insulator, these areas should be kept thin so the ground remains frozen. Banked snow can be pulled onto these areas later in the season if bare spots occur.

Some wet areas, such as springs or seeps, never freeze to any degree and should be of concern throughout the season, particularly if they result in ice flows. Sometimes these areas can be covered with wood chips or similar material to minimize the carryover of mud and dirt onto the adjacent trail surface. However, before using wood chips or similar materials, be sure to check with the land managing agency for their approval. The best scenario is to avoid these types of areas if at all possible with the trail route.

CHAPTER QUIZ

1. Ensuring the safety of groomer operators includes:
 - a) making sure they are prepared for trouble by carrying safety and emergency equipment
 - b) providing them with communication equipment and requiring them to file a “trip plan”
 - c) a good preventative maintenance program
 - d) requiring that they wear seat belts
 - e) a and b above
 - f) a, b, c, and d above
2. New equipment helps compensate for poor equipment operators. True False
3. Budget, weather, and traffic patterns should be considered when developing and managing weekly grooming schedules. True False
4. Groomer operators should never operate equipment while under the influence of drugs or alcohol because their abilities and judgment will be impaired. True False
5. When parked on the trail, always shut the groomer’s lights off to avoid blinding or distracting oncoming snowmobile traffic. True False
6. A Grooming Manager:
 - a) is someone who directs all aspects of a grooming program and establishes priorities and schedules
 - b) is an important position for a successful grooming program
 - c) is anyone who wants to be in charge
 - d) should understand heavy equipment operation and maintenance, understand snow mechanics, and be able to work with people
 - e) a, b and d above
 - f) all of the above
7. A mid-day grooming in high traffic areas may be useful to keep moguls from getting too deep, but a second grooming should be scheduled that same night to provide better conditions and proper time for effective trail set up. True False
8. The following factors should be considered when establishing grooming priorities:
 - a) available labor and operating budget
 - b) number of groomers available
 - c) total miles/kilometers of trail to be groomed
 - d) snowmobile traffic patterns
 - e) locations of businesses, parking areas, and attractions
 - f) length of season, snow conditions, and weather patterns
 - g) all of the above

Chapter Four:

OPERATING GROOMING EQUIPMENT

As noted in Chapter Two, there are a very broad range of types and styles of grooming tractors, drags, and implements. Each has its own operating procedures and requirements, so it is important to become familiar with the peculiarities of all equipment by reading the equipment operating manual(s). The following tips provide valuable guidance for operators that should be followed, in addition to equipment specific guidelines and instructions provided by the manufacturer of the equipment.

General Operating Guidelines

How Much Snow is Required to Start Grooming Operations?

The amount of snow depth required to begin grooming operations will vary by area and is affected by the type of terrain and by the type of snow. Remember that it requires a lot more snow to safely and effectively operate a groomer than it does to operate a snowmobile. And it can be a good thing to let snowmobiles run on the snow first before you start grooming operations because it starts the de-aeration and compression process. Generally, at least 8 to 12 inches (20 to 30 centimeters) of wet snow on smooth terrain like a road is enough to begin grooming operations. However, if the snow is drier, or if the terrain is rough or uneven, at least 12 to 18 inches (30 to 45 centimeters) of snow (or more) may be required to safely begin effective grooming operations.

Best Grooming Temperatures

Generally when using a drag, grooming operations should be suspended when the temperature is below -25 degrees Fahrenheit (-32 degrees Celsius) or above +40 degrees Fahrenheit (+5 degrees Celsius) because it can cause snow to stick in the blades or build up on the packing pan enough of the time to make grooming a smooth trail impossible.

Wind and Shade Can be Beneficial for Grooming

Wind and the location or aspect of the trail to be groomed should also be considered. Wind, by blowing new snow into the trail, and overcast sky or shaded trail locations with cooler temperatures, can sometimes have a beneficial effect on grooming effectiveness.

Keep Blades Clean

It may be necessary to stop and scrape the frost or snow buildup off the blade(s) if they fail to scour (self-clean). {If this is a consistent problem, consider having the moldboard part of the blades – but not the cutting edge of the blades – covered with UHMW or a similar plastic material that will always scour and prevent frost or snow buildup.} If it appears that a good trail can no longer be produced, contact the Grooming Manager and consider shutting down until conditions improve. Night grooming can be the best way to minimize these types of effects from the weather.

Stay on the Trail!

It is essential to stay on the trail base at all times with the grooming equipment. If it is necessary to regroom a section of trail, find a place to turn around where there is ample turning room and it is known that the snow base will support the equipment. If in doubt, get out and walk to check the snow depth. If a turnaround is attempted in an area where the snow is deep and loose, there is a risk of becoming severely stuck. If possible, use areas where turnarounds have been made before.

Shut Down in Poor Visibility

There may be times when it becomes necessary to shut down on the trail because of poor visibility caused by high wind, heavy snowfall, fog, or a combination of these conditions. Simply stop the groomer right where it is and leave all lights on with the engine idling. If possible, contact the Grooming Manager or dispatcher to advise them of the situation and location. Always wait the situation out because it is easy to get off the trail in these situations which could result in trouble. Always stay with the equipment and wait for conditions to improve.

Watch for Snowmobiles

When operating grooming equipment, always watch for approaching snowmobiles. Particularly when the trail is narrow or winding, keep to the right, slow down, and, if necessary, stop when a large group is approaching. When approaching sharp or blind curves, always anticipate and plan for snowmobiles that may be approaching. Also watch for snowmobiles that overtake the groomer from behind. Again, keep to the right to allow them to pass. If the trail is narrow or winding, look for places to safely pull off enough to allow them to pass. If necessary, stop in an area where it is safe for them to pass and signal for them to proceed.

Grooming Basics

Building Trail Base vs. Maintaining Trail Base

Anytime there is “new” snow to work with, either through new snowfall, blown in snow, or snow that is pulled in from the trail edges, grooming will build (increase) the trail’s base/depth. If “new” snow is not available, grooming will simply maintain the trail base, which is a much less desirable situation. Remember that a drag’s blades must always have snow in them to accomplish either trail building or maintenance.

Ideal Groomed Trail Width

In most areas, the ideal groomed trail width will be 1½ to 2 groomer widths (typically 12 to 18 feet or 3.7 to 5.5 meters). However, local conditions and equipment widths will dictate what this means on any given trail segment. The clearing width in some wooded areas may only accommodate a single drag width, while other trails located on improved roadways may provide as much as 60 feet (18 meters) of width. However in these situations on wide roads, do not try to groom too wide. Pick a route and stick to it to ensure that the trail base is built from the ground up. If varied routes are groomed on wide roadways, it can result in soft pockets of snow and rough trails because the same

designated trail route was not consistently compacted. By keeping the groomed route on these wide roads narrower, the middle of the road/trail can be hardened and result in a better quality trail.

Stay to the Right

Always groom on the right side of the trail with the direction of snowmobile traffic. Take the right side of the trail and stay there. Then reverse the grooming direction the next time in order to widen the trail, rather than grooming against snowmobile traffic on the wrong/left side of the trail. Never groom against traffic on a one-way trail.



Photo 4.1 Always groom on the right side of the trail

Constantly Watch Behind

Constantly watch in the rearview mirrors to monitor the finished product on the trail behind the groomer. When using a drag, this is particularly important since the drag blades can quickly empty out and go from totally full to totally empty within a few seconds or over less than 15 feet (4.5 meters) of trail. This can mean spending as much as 75% of the time monitoring more closely what is happening behind the tractor versus in front of it. Leave the tractor periodically and walk back to check the finished trail surface behind the groomer, especially at night.

Photo 4.2 Use the rearview mirrors to constantly watch behind the groomer to monitor the quality of the finished trail

Know the Trail and Anticipate

Operators must know their trail to be able to *anticipate* the need to carry extra snow, either with the front tractor blade or in the drag, as they approach areas that are bare or may be in need of additional snow to establish a good trail base. Such areas can include creek crossings, bare hill sides, windswept or sunny areas, areas of rough or rocky terrain, the crown of hills or approaches, the bottom of curves, etc. If the operator doesn't anticipate and plan ahead, it will be too late to improve the trail defect once they're at it. So when going through a dip, swale, or ditch that the drag spans or bridges, anticipate the need to lower the drag blades before getting there to gather snow. Conversely, when approaching a particularly drifted or



deep snow area, a steep hillside, a switchback, or a road crossing, anticipate the need to make upward adjustments to the blade depths (front and/or drag) in advance of the location to avoid getting in trouble by spinning out or getting stuck.

Pay Attention on Curves

Pay special attention to curve berms and try to work down the high outside edges. Be careful not to completely straddle these berms or the tractor may get high centered. A drag will not usually stay on the side of a sharp curve's snow berm. So the grooming drag must be either at the top or down in the bottom of the curve. It is often best to pull snow into the bottom of the curve with the front tractor blade and then work the new snow in the bottom of the curve with the drag or tiller.

Take the Time to Do It Right

Take the time necessary to get a smooth trail by regulating the speed of the tractor and cutting depth of the implement according to trail conditions and grooming needs. If there is a particularly rough area and a place to turn around, groom the trail a second time.

Remove Back Up Piles

Whenever it is necessary to back up on the trail, be sure to remove the pile of snow or tire ruts that backing up can often create since these piles can become extreme safety hazards for snowmobilers, particularly once they freeze. This requires either re-grooming that section of trail or removing the snow pile with a shovel.



Photo 4.3 Remove back up piles! Use SMV sign.

Think Visibility!

Grooming tractors should be operated with their warning beacon/strobe and lights on at all times to increase their visibility to snowmobilers approaching on the trail. A slow moving vehicle (SMV) sign should be displayed at the rear of all units since a groomer is nearly stationary when compared to a fast moving snowmobile.

Beware of Dirty Snow

Remember that dirty snow can deteriorate rapidly with any sunlight (solar radiation) which can affect the firmness and overall quality of the trail base. Try to pull snow from the sides of the trail to cover up dirt and to mix with the old snow on the trail. This can sometimes be done with the front blade. Oftentimes it can be accomplished by simply running the tracks of the tractor about four inches further to the right, onto the berm at the outside trail edge, which can cause “new” snow to fall onto the trail.

Don't Leave Holes in the Trail

Never leave holes caused by being stuck, drag malfunction, or operator error in the middle of the trail since holes can be a hazard and can cause injury to unsuspecting snowmobilers.



Photo 4.4 Don't leave holes in the trail

Cover Ice

Cover icy spots with snow if possible. Sometimes icy spots can be scored with a scarifier blade to aid in traction and steering and also to help try to process it into the snowpack.

Groom Bridges

Groom bridges! All too often operators fail to *groom* across bridges. This can lead to extremely rough and unsafe trail conditions before, across, and after bridges. Start by simply “panning” across the bridge at the beginning of the season to prevent damaging the bridge’s deck. Use the groomer to bring snow onto the bridge if needed and eventually build the trail base to a depth that can be regularly groomed.

Tips for Effective Grooming With a Drag

Remove Air from Hydraulics and Compensate for Leaks

After hooking the drag to the tractor, activate the hydraulic controls in the cab of the tractor to raise and lower the drag a few times to remove any air that may have entered the hydraulic hoses and cylinders. Inspect all connections for leaks. If there is even a slight leak, promptly fix it to prevent spilling hydraulic fluid into the snowpack and potentially harming the environment. Until the leak is fixed, remember that the loss of pressure can cause components to settle, which may require compensation by continually adjusting (raising) the drag component controlled by the leaking hydraulic.

Check for Clearance and Binding When Turning

Carefully inspect the hydraulic hoses for binding and interference as the tractor unit is turned. Check for clearance between the outside of the tracks and the outside front of the drag when the tractor unit is fully turned.

Pay Attention!

Operating trail grooming equipment is a demanding job that requires the operator’s undivided attention at all times. While it is important to be watching the trail ahead to observe changing conditions, it is almost more important to watch what the grooming drag behind is doing. Don’t simply drop the drag and forget it. Instead, it requires that the operator constantly respond and adjust to ever-changing trail and snow conditions.

Keep the Mirrors Clean and Use Them

Keep the rearview mirrors on the tractor clean in able to constantly monitor how the snow is processing in the drag blades, as well as the finished surface behind the groomer.

Get Out and Check the Trail

Get out of the tractor to occasionally to walk across the groomed surface. Check trail consistency by scuffing across the finished product with a boot. If the operator sinks, recheck groomer settings to ensure good processing and compression of the snow.

Remove the Entire Mogul

Moguls and drifts should be completely cut away from the trail's snow base. If only partial cutting occurs, the resulting uneven density can allow moguls to reform quickly. Typically, the greatest cutting depth is needed on curves and in other areas with deep moguls.

Watch the Speed

The effective grooming speed when using a drag is typically in the 5 to 7 miles per hour (8 to 11 kilometers per hour) range and is primarily governed by the way the snow is being processed by the drag. Too slow, and a rolling action in front of the blade will not be adequately established. Too fast, and the drag will bounce leaving a poorly groomed trail. It will also spray snow outside of the drag, wasting it. Excess speed can prevent the blades from properly cutting off the mogul and also not give snow the time it needs to fall out into a dip or hole. Slow down and take the time necessary to get a good finished product that will stand up better to traffic. Grooming too fast is a much more detrimental factor than most operators realize and can be a huge waste of grooming resources.



Photo 4.5 Keep processed snow inside the drag!

Slow Down When Using Wheels Kits

Use the wheel kit on the drag to cross sections of trail where bare ground is showing. Be sure to travel at a slow rate of speed since the drag frame can do a lot of twisting if on rough ground. Traveling too fast with the wheels down can cause stress fractures in the hitch assembly and frame or twist the drag frame so that it will no longer be square.

Groom at Night or When Traffic Is Low

Always try to groom when traffic volumes are at their lowest, which is typically at night. This helps allow adequate time for the trail to set up properly and can also enhance grooming and snowmobiling safety. On heavily traveled trails, this could be a window of

time as narrow as 2:00 AM to 6:00 AM on weekends. Grooming at night will generally produce the best quality trail since temperatures are typically colder which can help the snow flow better and set up harder. However, the greatest single key to effective grooming is low traffic. So if traffic is heavy, consider an alternate time to groom.

Early Season Cautions

If the grooming program has more than one drag, use an old drag for early season trail set up to avoid damage to the better equipment. Go slower than usual because of the possibility of hitting hidden hazards. Sometimes it is better to “ride the pan” or use a compactor bar in these conditions rather than try to cut much with drag blades.

Pull Snow to the Middle of Trail

If there is a lack of snow in the middle of the trail, which is often the case since that is where snowmobiles most often operate, use the front blade to pull snow in from the trail’s outer edge or operate the drag on the outer edge of the trail. The outside two to three feet (0.6 to 0.9 meter) of a trail will often be softer than the middle of the trail due to the compaction that snowmobile traffic contributes in the middle of the trail.

Remove Debris from the Trail

Stop to remove significant rocks, logs, limbs, or other debris that is laying on or in the trail surface. Debris can not only be a hazard, but can also attract heat which can have a thawing effect on the surrounding snow trail surface.



Photo 4.6 Remove debris from trail.

Watch the Temperature

The best temperature for grooming with a drag is generally in the +5 to +25 degrees Fahrenheit (-15 to -4 degrees Celsius) range.

Generally, wet snow grooms best at night and dry snow best during the day, *if* the traffic level is low. Oftentimes, early evening has the best temperatures for effective grooming.

Use Wax or Silicone Spray to Help Blades Scour

In warm weather, consider using snowplow wax or silicon spray on the drag blades to temporarily prevent the snow from sticking to the blade. Air that is significantly colder than the snow can also cause frost to form on the blades and prevent them from scouring (self-cleaning). This is a greater problem with single blade drags since the blade *must* scour for the drag to work. Multi-blade drags also have a greater tendency to self-scour. If this is a continual problem in the area, consider covering the moldboard portion of the blades with UHMW or a similar plastic covering which will prevent snow sticking to the blades. If it is either so warm or so cold that snow continually sticks to the blades and they will not scour, grooming operations should be suspended.

Don't Dump Snow on Road Crossings or Driveways

Use care to avoid dragging or dumping snow on roads or driveways when crossing them with grooming equipment. Frozen piles of snow deposited on roads can be hazardous to motorists and cause ill will toward snowmobiling. Likewise, piles of snow deposited in driveways can strain relationships with adjacent landowners by making access to their property difficult.



Photo 4.7 Never leave piles of snow on roads

Always cross roads and driveways with care and use caution for oncoming vehicles. Wheels on a drag should always be DOWN when crossing roadways. If a pile of snow is left on the road, it may require the operator to stop and clear the road or driveway with a shovel, but they should be cautious of oncoming traffic.



Photo 4.8 Always raise the drag to cross roads

Don't Dump Snow on Railroad Crossings or Railroad Tracks

Use care to avoid dragging or dumping snow on railroad crossings or on railroad tracks when crossing them with grooming equipment. Frozen piles of snow/ice on the tracks can derail a train and result in significant property damage. It may require the operator to stop and clear the tracks with a shovel. Always cross railroad tracks with care and use caution for approaching trains since the groomer is likely very slow moving in respect to high speed trains.



Photo 4.9 Use care to not create snow/ice buildup on railroad tracks

Don't Set the Drag Blades Too Low on Smooth Trails

When grooming a trail with little fresh snow cover and only minimal moguling, care should be taken to not have the drag adjusted too low because it would unnecessarily process the hard-packed trail base. Cut only as deep as the bottom of the “dip” of the moguls. If the trail is relatively smooth, only cut or “skim” with the rear set of blades. Following this method can help build/increase the depth of the hard-packed trail base.



Photo 4.10 Use only the rear set of blades to groom minimally moguled trails.

Deep New Snowfall Can Mean Starting Over

Moguls under a deep new snowfall cannot usually be completely removed. Process the fresh snow and compact it so a smooth finish is established as a new base on top of the moguls. Two passes may be required to achieve sufficient processing and compression when there is extremely deep new snowfall. A longer set up time will be required.

Grooming Wet Snow

Processing wet, heavy snow is more difficult and requires more operator finesse since it has more surface tension and will not flow as well as cold, dry snow. To groom in wet conditions, adjust the drag somewhat higher than if in below freezing conditions and pick up the speed of the tractor slightly. Monitor the snow to ensure it flows freely. If the snow begins to collect in the drag, raise it high enough to clear the snow and lower it again, but make sure not to deposit a hazardous pile of snow on the trail when doing so.



Photo 4.11 Don't leave a hazardous pile of snow in the trail when adjusting a drag

Continually Monitor the Drag Blades

Particularly when grooming trails that are relatively smooth and only lightly moguled, operators must continually adjust the drag's cutting height. This need is different for multi-blade versus single blade drags:

Multi-Blade Drags: The weight of the drag causes natural settling which forces the cutting blades deeper as the frame and side rails settle. This requires that the operator must pay attention to monitor the height and readjust the drag *upward* as needed.

Single Blade Drags: The blade must exert constant down pressure on the snow surface. When the trail is relatively smooth, this can result in the lone cutting blade being forced upward. As a result, the operator must monitor the setting and readjust the blade *downward* as needed. Additionally, when using a single blade drag the operator must understand that the typically concave shape, (), of the blade lends itself to drafting and being sucked downward, particularly when encountering a soft pocket of snow in the trail base. Beware that this can cause springs to trip and create humps in the trail.

Adjusting Blade Height

The procedure for making adjustments to the blade height varies slightly between a multi and single blade drag:

Single Blade Drag: Set the drag blade to cut or dig enough to keep the area in front of the pan full of snow, but not so much that snow is spilling out the sides of the drag and being wasted. The snow in front of the blade should be kept rolling or moving constantly. The blade depth will typically vary from ¼ inch (0.6 cm) to a maximum of about 2 inches (5 cm). A quick, short bump of the hydraulic control lever is all that is needed to raise or lower the blade ¼ inch (0.6 cm) to ½ inch (1.3 cm), which will often be sufficient. Raising the blade too much, too quickly, can leave a bump in the trail. Also remember that the single blade drag's packer pan will ride up and over whatever goes under the rear blade. So be cautious to not inadvertently create humps in the trail by raising the blade too quickly.

Multi-Blade Drag: It takes even less than a “quick, short bump” to adjust the cutting height of a multi-blade drag. Essentially all that is needed is to barely crack the hydraulic spool open, to when it just barely “squeals,” to likely have all the adjustment that will be needed. Since the cutting depth of the blades are preset and stepped down from the front to rear of the drag, it requires lowering or raising the side rails only a fraction of an inch/centimeter to substantially change the cutting depth of the drag. Additionally, since the side rails keep snow contained within the drag versus allowing it to spill out the sides, it is good to keep a significant supply of snow in front of the rear spreader pan because it helps to continually build/increase trail base and will not create “humps” like a single blade will.

Spilling Snow Equals Carrying Too Much

Particularly with single blade drags, when the snow that has been built up in front of the drag blade isn't rolling or churning or is spilling out the sides, the drag is carrying too

much snow and is not working effectively. In most cases, a very slight tap of the control lever is all it takes to make a significant change in the amount of trail base the drag is cutting and will correct this situation.

Grooming Hills

Hills can create another special challenge for groomer operators. There is likely to be a lack of snow at the crest/top of the hill and an abundance of snow at the bottom. Oftentimes, the hillside may be either icy, or even bare, from snowmobiles spinning their tracks while climbing it. It may also be bare due to southern exposure to the sun. As much as anywhere, hills are an area where the operator *must* anticipate and plan ahead. Also, always keep to the right so the groomer is not a hazard.



Photo 4.12 The crest of a hill often needs snow

The drag may need to be raised as the groomer begins climbing a hill. In Photo 4.11, the tracks of the tractor have spun and dug trenches, which the drag can fall into unless it is wider than the tractor. Note that the side rails of the drag have nearly disappeared below the surface of the trail, which can result in the tractor quickly becoming stuck while trying to pull the drag uphill. Anticipate this ahead of time and adjust the drag's cutting height upward to lighten the load.



Photo 4.13 Beware of trenches dug by spinning tracks

Grooming Curves

Curves can create special challenges since there is typically low snow or no snow in the bottom of a sharp curve. At the same time, berms three to five feet (0.9 to 1.5 meters) high (or more) can form on the outside edge if the curve is not regularly groomed and reformed. First, always beware that dropping too far down into the center of a sharp or blind curve can be dangerous for approaching snowmobile traffic. Therefore, never deviate over/inside the mythical centerline of the trail by more than a couple of feet so as to still allow room for an oncoming snowmobile to meet and pass the groomer in the curve. Second, if the groomer gets too high on the outside edge of the berm, it risks

becoming high centered and stuck. Use the front blade on the tractor to pull snow from the outside berm into the bottom of the curve. At the same time understand that it is difficult to “carry” much snow into the curve with a multi-blade drag because of its tendency to build trail depth versus “carrying and dumping” snow like what can be done with a single blade drag.



One other thing to keep in mind about grooming curves is that there is only one location in a curve where there is ever “extra” snow that may be available for the drag to move into the snow-deprived bottom of the curve. That location is the outside end of the curve and, sometimes, some of it can be tapped on the next reverse direction grooming pass. This is further explained as follows: Imagine the curve as an upside down U, like this: \cap . The direction of travel and grooming is counterclockwise, on the outside/top edge of the curve, which means any “extra” snow will be deposited on this grooming pass by the drag at the *end* of the upper left corner of the \cap , where it transitions from curve to straightway. If the grooming direction is reversed on the next shift (by grooming clockwise on the trail loop), the groomer will be on the inside/bottom of the curve as it enters the curve. By moving over to the left a couple of feet/half a meter (but no more so as to not create a safety hazard!) as the groomer approaches the curve, the drag can be swung slightly into the area with the extra snow, which is slightly *before* the outside left corner of the \cap . Then, by dropping back into the bottom of the curve, the groomer can deposit any snow that was picked up with the drag into the bottom of the curve. This is a slow process, but by keeping at it, trail conditions on curves can be slowly improved.

Photo 4.14 Sharp curves typically have little snow available at the inside/bottom

Making a Double Pass

If there is a safe, firm place to turn around, it can be desirable to groom a “double pass” on a particularly rough, moguled area. Since this means the trail section will essentially receive three grooming repetitions during the double pass, use the following procedure to make this effort as efficient and effective as possible: On pass number one (the normal route/repetition through the section), go a little faster than normal, drop into the bottom of curves, and don’t spend extra time grooming. On pass number two (the return route after the turnaround), again make it quick without a lot of extra grooming effort. On pass number three (the return/second repetition on the original rough section), really slow down, work the trail carefully, and vary the position of the groomer as needed to take advantage of windrows/berms of snow that were created by passes number one and two.

Proper Use of the Front Blade

Don't Over Use the Front Blade

When using a drag, the front blade of the grooming tractor is best used to level drifts or to pull new snow into the trail. Snow worked by the front blade is then processed, compressed, and leveled out by the drag. Operators are cautioned to not “over groom” by continually raising and lowering the front blade which can lead to accentuating dips and rolling trail surfaces. Rather, trail leveling is best accomplished by the planer effect of a drag pulled behind the tractor. When using a tiller, the front blade must perform the important process of removing moguls, so the front blade needs to be in use nearly fulltime. Still, overworking (too frequently raising and lowering) the front blade can lead to uneven trail surfaces and should be avoided. Try to use the tilt adjustment instead.

Beware of Hazards

Be extremely careful to watch for rocks and tree stumps when working with the front blade. Hitting these hazards can put a great deal of stress on the tractor, particularly on the steering mechanisms of some units. If the vehicle's blade or tracks hit something, let go of the steering wheel momentarily – this can reduce stress on critical parts by allowing some give in the steering system.

Cutting Tracks across a Side Hill

The front blade on a tractor can be used to cut a new track across deep snow on an inclined slope. The most effective method is to approach the upper steeply inclined slope transversely and to use the laterally swiveled blade to push snow, thereby creating a flat track in front of the tractor. Start by using a small amount of snow and then use more and more snow as the tractor progresses. The snow pushed downhill will broaden the track and provide greater safety.

Blade Use at Grooming Speed

While operating the tractor *at grooming speed* when using a drag, it is recommended to run with the bottom of the front blade set about 4 inches (10 cm) above the bottom of the tracks, not at ground level. This can allow it to be used for day-lighting out finger or pillow drifts, while at the same time keeping it a safe distance above the trail bed and away from rocks, stumps, and other hazards.

Watch *behind* the front blade to monitor the blade height in relation to the bottom of the tracks. If there is a



Photo 4.15 Watch *behind* the front blade to monitor blade height relative to track location

need to use the front blade for heavy dozing or for building trail across a drifted side slope, slow down and operate with caution.

When using a tiller, it is recommended that the front blade should always have snow in it since it must cut the moguls away. The blade then feeds snow to the tiller for processing. It is important to know the trail and the snow depth. If snowfall is low or if there is uncertainty about the trail location or potential hazards, slow down and operate with caution.

To flatten low moguls or ripples, the vehicle should be driven with the front blade in what is commonly known as the “float” position. In this position, the blade is open with its own weight on the ground and hydraulic down pressure is not created.

Larger moguls should be approached at approximately half the mogul height and not in the float position so that snow falls forward into the dip behind the mogul. If possible, the cutting depth should be set using the tilt cylinder on the blade and preferably not using the up and down motion of the blade. The former method will help produce a smooth surface while an “up-down” adjustment can contribute to rough or undulating surfaces.

Using the Front Blade to Assist with Climbing

When working with fresh, deep snowfall, the front blade can be important to obtaining good weight distribution, particularly if using a tiller, as well as to obtaining good contact pressure on the snow with the grooming unit. The front blade can be used as a climbing aid when traveling up steep slopes when the operator stops just *before* the unit digs itself in. The operator then drives backwards with the blade lowered which helps smooth out the step. When starting off again with the blade raised, the driver can typically get a little further thereby helping to overcome uphill gradients that might otherwise be difficult to handle.

When descending steep slopes, the front blade may also be useful as a braking device.

Tips for Grooming With a Tiller

Preparing Fresh Snow

Fresh snow initially creates a generous crystalline microstructure that is more or less jagged. Fresh snow should be worked as gently as possible since snow crystals are destroyed if a tiller is used too aggressively, causing snow crystals to no longer bond with one another and to become slush. Fresh snow/powder snow consists of snow crystals which hang together loosely and thereby enclose a lot of air. When preparing this type of snow, part of the air is driven out and the crystals are pressed closer together, which gives the snow a load bearing coating.

Processing Moguls

Moguls are sometimes formed as snow crystals melt as a result of water film formation occurring from traffic on trails. This can result in a combination of ice slabs and also

softer areas (moguls) as snowmobiles break the top layer of snow. Ideally, old and relatively “fresh” snows (snow crystals) are mixed to produce a durable trail. When temperatures are sufficiently low, the snow freezes into chunks.

The tiller’s teeth smash the chunks of snow into slush, which fills the gaps on the surface of the trail. This processed snow/slush is then shaped by the finisher/comb and bound together by water film formation. As the chunks are smashed, the snow crystals are also destroyed so bonding only takes place to a limited extent. This is why slush can only be created from ice and never from powder snow.

A durable snow surface is only produced as a result of mixing the processed snow with fresh snow and/or by mixing the snow on top of the trail with old snow which is lying at lower levels, beneath the top of the trail surface, and has not yet been used.

Processing Icy Surfaces

Icy trail surfaces should only be broken open if the snow coating is strong enough or if fresh snow has fallen. Slush created in this way will only bond with fresh snow or water – again forming ice. Ice slabs formed in snow surfaces which are otherwise good can be processed by mixing them with snow crystals lying deeper in the snow. However, the more frequently the snow is turned over and the crystals are destroyed, the less the crystals will bond together.

Processing Wet Snow

A relatively hard surface may be formed on the snow surface as the result of high humidity which can cause a film of water to develop on the finisher/comb. Sometimes tilt options on tillers can be used to cope with this to help break up this glazing effect.

Processing Extreme Sugar Snow

When grooming in conditions where there is extreme sugar (very fine, dry) snow, particularly in the spring, it may be desirable to use only a smoothing board. Operating the tiller in these conditions can create “side walls” caused by banks of snow spilling out the sides of the tiller. When sugar snow has fallen, it is difficult to create a durable snow surface. Therefore it is a good idea to leave the snow alone for two or three hours, until the temperature changes, so that crystals can form.

Control the Ground Speed

The goal of trail grooming is to create a snow surface that is smooth and even. If the tractor is driven too fast, the tracks will throw snow out to the side and also over the top of the tiller onto the snow surface which has already been prepared. Too fast of a speed can also cause the tiller to bounce and sway, resulting in an uneven surface.

Operate Only with Sufficient Snow Cover

Never operate the tiller until snow cover is deep enough to prevent damage to under-lying turf and to the grooming unit. When possible, create snow reserves in critical areas where snow may melt back and expose bare ground.

Proper Tiller Depth

Indications that the tiller depth is set correctly include:

- perfectly clean snow surface behind the tiller
- the snow surface retains a firm base
- economical operation of the grooming unit
- favorable loading for the tractor and tiller

Indications that the tiller depth is set incorrectly include:

- rotary shaft set too high: no output visible behind the tiller
- no marking at hard points on snow surface
- rotary shaft set too deep: too little snow through-flow, so snow flows out of the side of the tiller and forms a side wall
- snow crystal bonding and the base quality deteriorate
- large amounts of power required – not economical

Side Walls Being Formed by Tiller

Side walls being formed to the left and right of the tiller indicate:

- excessive groundspeed
- excessive engine speed
- tiller depth set too deep
- contact pressure position switched “ON” rather than in “Float” position
- cylinder equipment carrier has been adjusted
- rotary shaft is at a standstill
- the lateral finisher/comb must overlap the prepared track to ensure that the transition between tracks occurs in a clean manner

Don't Leave Holes or Piles of Snow

Any holes in the trail surface and/or piles of snow created when driving or turning the unit should be flattened out again as quickly as possible.

Trail Surface Does Not Look Good

When parts of the trail do not look good, like they were not processed and finished okay, it may indicate:

- the tiller is set too high – check shaft depth adjustment
- engine speed too slow
- lever not in engaged (float) position
- excessive groundspeed
- failure to use front tractor blade to create an even surface area on the trail, so the tiller is lying “open” on moguls



Photo 4.16 Properly finished trail

Remove Snow from the Unit

Regularly remove snow that can build up on the loading/cargo area of the tractor since the increased weight will cause increased levels of fuel consumption, as well as affect the unit's center of gravity.

Groomer is Almost at a Standstill

If the vehicle is almost at a standstill, it may indicate:

- tiller is set too deep – check shaft depth adjustment
- excessive engine speed
- cylinder equipment carrier adjusted by mistake
- direction of tiller rotation set to contra-rotation
- rotary shaft at a standstill (jammed, crushed, frozen)

Violent Vibration When Tiller Turned On

If there are violent vibrations in the vehicle when the tiller is turned “ON,” it may indicate:

- the shaft is unbalanced
- a gear is missing as a result of improper maintenance
- snow is frozen on the shaft

Unbalanced means vibration – screws unfasten themselves and bearing can be destroyed. This is unsafe, so ALWAYS rectify imbalance immediately.

Operating on Hills or Steep Slopes

When driving uphill, always only drive with the amount of power necessary and watch out for track engagement/traction. If excessive power is used, the tracks will spin and/or the entire machine will dig itself in. If the tracks begin to dig themselves in, stop immediately and look for a new route.

When driving downhill, always drive at a moderate speed to ensure the engine does not over-rev, the unit does not drift sideways in an uncontrolled manner, and that it does not pull snow down the slope behind it. Drive with as few steering movements as possible while ensuring that both tracks are turning. Speed must be reduced when driving over hilltops to ensure the machine tilts forward in a controlled manner to ensure the front blade does not “stick in the ground” and the tracks do not slip.

If, when driving downhill, the tractor should start to slip and drift sideways to the left or right (vehicle's longitudinal axle at right angles to the fall line of the hill), immediately counter-steer up to the point where the tracks contra-rotate (by turning steering wheel to the left or right until it locks) to ensure that the vehicle's longitudinal axle is again pointing in the direction of the fall line. Briefly increase speed to do this. When the vehicle is slipping in the fall line, reduce the slipping movement by changing over (reversing) the rotary shaft direction of the tiller and by carefully using the front blade as an anchor point. Continue to do so until the vehicle is stabilized.

Tips for Operating Tracked Vehicles

Keep the Vehicle on Top of the Snow

Snow can have a top crust that is harder than the underlying base due to various melt-freeze or wind-packing conditions. It is to the operator's advantage to try to keep the groomer on top. Try to not spin the tracks through that crust if at all possible.

If Stuck, Don't Spin

If the groomer gets stuck, DO NOT spin the tracks. It is important to remember that a tractor is rarely stuck in a level position, unless it has spun out while climbing a hill on a hard packed, icy trail. Raising the implement and backing the unit down the hill will often remedy this situation. If not, the groomer is stuck, so proceed with caution.

More often than not, the tractor will be tilted to the right / outside edge of the trail because it fell off the compacted trail base. The first thing to do is get the tractor level. This is particularly true with gear drive tractors since the lubricants can run out of the differential into the axle tubes that are lower, which can leave the ring gear and pinion empty or low of grease. In such cases, spinning the tracks is the last thing that should be done since it can severely damage the tractor. Get the tractor level to protect it. At this point, a long handled, plastic scoop shovel is the operator's best friend, and they should start digging. The tractor will most likely be high-centered, so snow must be removed from beneath the tractor's front blade, frame, and undercarriage.

Once the tractor is level, the vehicle should be rocked *gently* back and forth which can help pack the snow. It is better to unhook a drag sooner versus later – it can save a lot of time, effort, or even damage to the equipment. If that doesn't work, a winch or come-along may be needed to free the vehicle. Otherwise the operator must shovel some more.

Use the Contour of a Hill or Winch It

If uphill travel is too steep, try to travel at an angle around the hill that uses ground contour to your advantage. Look ahead and plan the route. If the vehicle has a front blade, tilt the blade to the uphill side to move snow to the downhill side. This will place snow under the downhill track and build a bench to travel upon. If this is not possible, a winch may be needed to assist the groomer with climbing the hill.

Descend in Low Gear

When descending steep grades, use a sufficiently low gear and always keep the tracks revolving to permit steering. A good rule of thumb for descending steep grades is to use the same gear as is required for climbing the hill.

Raise the Drag in Deep Snow

In deep snow or in drifts such as can occur along fence lines or in a road ditch, raise the drag to prevent too much snow buildup. Also remove accumulated snow from the pan. If track slippage occurs, try to wriggle the unit through the excessively deep area of snow.

Steer Clear of Tree Wells

Beware that snow next to tree wells can be soft due to thawing and lack of stability on the sidewalls. The groomer can quickly become stuck if it slips into one, so stay as far away as practical from them. It may be best to test the edge first by a “walk around.”

Tips for Avoiding Equipment Damage

Always Follow the Manufacturer’s Recommendations

Always check and follow the manufacturer’s guidelines for operation and maintenance. The fact is it’s easier to preserve what you have than to restore what you’ve lost.

Proper Track Tension

There is always potential to have a track come off any tracked vehicle. This most commonly occurs during aggressive side hill operations or from hitting the edge of a stump, rock, or ditch with the track. Proper track tension adjustment is particularly important and can help prevent losing a track.

Warm Up the Engine

When starting a turbocharged diesel engine, use the hand throttle to run it at *just above idle* for a few minutes before beginning to work the machine. (A diesel engine will not warm up properly at just idle, so ensure it’s *just above idle*.) Never go from cold start to high power immediately. Also, always allow the engine to operate at an idle for ten minutes before turning it off to allow the turbocharger bearings to be cooled by the circulation of the engine’s oil. Also allow the engine to operate at a fast idle, without lights and electrical load, before shutdown to recharge the batteries.

Respect the Torque

Tracked vehicles are designed to be as lightweight as possible to maintain correct ground pressure. However, they also produce a substantial amount of torque in order to pull the required loads. The availability of significant torque must be respected as it is quite possible to overstress the unit and create hairline fractures or misalignments. Be especially careful when stuck or when moving rocks or trees off the trail. (Remember – the tractor is not a bulldozer so this is NOT recommended. If it is necessary to do this, use extreme caution to ensure the tractor is not damaged.)

Don’t Run Hydraulics Over the Relief Pressure

Do not keep hydraulics running over the relief pressure during normal operations. If the hydraulics squeals, back off the control. Running hydraulics past the limit (exceeding relief pressure) causes excess heat and can lead to various mechanical problems.

Come to a Full Stop Before Shifting to Reverse

Do not shift from forward to reverse while still in motion. This type of shifting can cause failure of the transmission, driveline, U-joints, tracks, or differentials. Always allow the engine RPM to return to idle before shifting from forward to reverse.

Manually Shift Automatic Transmissions

Don't lug the tractor engine. For best performance, it is best to operate at the peak of the horsepower and torque power curves. One way to ensure this is to manually shift automatic transmissions so that an engine RPM of at least 2000 to 2200 is consistently maintained.

USE IT, DON'T ABUSE IT!

Ten Common Operator Abuses

The following are ten common operator abuses of tracked snow grooming vehicles that can lead to premature equipment wear and equipment failure:

- 1. Failure to Perform Proper Warm Up.**
Neglecting warm up procedures can impair control responses and cut down on the life of the engine and transmission. Start the vehicle and check the steering, hydraulics, brakes, tracks, frame, attachments, etc. while it's warming up for at least 5 to 10 minutes.
- 2. Failure to Perform Walk-Around Inspection.**
There is no replacement for an operator's daily start up inspection. The operator must be very familiar with the machine. With daily inspections, the operator has the opportunity to check for loose fittings, bolts, oil leaks, and other problems that can be easily corrected and help prevent a major problem from developing. Have a checklist for each unit. Also stop each hour during operation and walk around the machine for a general visual inspection.
- 3. Operating When Repairs are Needed.**
If a vehicle is operated with known problems, even minor ones, it unnecessarily risks the vehicle's integrity and the operator's safety.
- 4. Operation Without Proper Training.**
Untrained operators, or even experienced equipment operators who are unfamiliar with the vehicle, may overload the equipment which can cause stress and damage the vehicle. An important part of every operator's training should be to read and understand the operator's manual before operating the equipment. Operators must always be attentive to odd sounds and the vehicle's response to controls.
- 5. Misapplication of Equipment to Job.**
All too often, tracked vehicles are used for purposes they were not designed for. A grooming vehicle is not a bulldozer and should not be used as one. Knowing and respecting the limits of the vehicle's capabilities is important to protecting the life and usefulness of the tractor, as well as the safety of the operator.

- 6. Going Too Fast.**
Tracked vehicles are designed to pull heavy loads at relatively low speeds. Operation at a high speed over rough terrain can damage the tracks or drive train and can also cause excessive vibration that can harm the tractor's frame and components. Additionally, working in too high of a gear overworks and overheats the transmission. It also generally produces a poorly groomed trail. Operators who chronically groom too fast should be replaced since they put the equipment at risk and produce poor quality trails that do not stand up well to traffic.
- 7. Unauthorized Modifications.**
Some operators believe that modifications to their equipment, like resetting hydraulic pressures or recalibrating the fuel pump for more horsepower, are smart moves. In reality, unauthorized modifications like these will often stress the vehicle beyond its limits. This can result in warranties being voided if a failure occurs or shorten the normal life cycle of the vehicle. Always check with the manufacturer before making any modifications to grooming equipment.
- 8. High Temperature Shutdown.**
Not allowing the engine temperature to stabilize before shutdown can damage turbochargers and cause premature engine wear. Always allow the engine to idle for 5 to 10 minutes before shutdown. This also provides an excellent time to perform a walk-around "shutdown inspection," as well as a time to warm up the operator's vehicle for the drive home.
- 9. Unfamiliarity with the Trail.**
Operators who are unfamiliar with a trail can run into sudden hidden dangers such as rocks, trees, wet areas, and steep grades that can pose a threat to themselves and the vehicle. Operators who helped construct the trail or who performed summer maintenance on the trail are a valuable asset since they know what the area looks like without snow cover. They are also the best people to have set the outer edges of the groomed trail at the beginning of the season. Know the trail and stay on it. Groom with a plan and stick with the plan. Operators should follow the trail signs and NEVER follow snowmobile tracks through open areas unless they're absolutely certain that is exactly where the trail is located. Snowmobilers often shortcut bends in the trail and can get the groomer into extreme trouble if it follows them off-trail.
- 10. Using Attachments Improperly.**
Even if the front blade can remove a large drift in one pass, make several passes and do it in smaller, less stressful cuts. Saw limbs into several small pieces before pushing them off the trail with the front blade. Use it, but don't abuse it!

CHAPTER QUIZ

1. The ground pressure and weight of a grooming tractor allows it to safely cross frozen bodies of water. True False
2. The faster the grooming speed, the better the trail quality and durability will be. True False
3. The amount of snow depth required to begin grooming operations will vary by area and is affected by the type of terrain and by the type of snow. Generally, there should be at least ____ of snow to begin grooming operations that are effective and worth the cost of grooming.
 - a. 2 inches (5 centimeters)
 - b. 6 inches (15 centimeters)
 - c. 12 inches (30 centimeters)
 - d. 18 inches (45 centimeters)
4. The faster the grooming speed, the better the trail quality and durability will be. True False
5. Groomer operators should pay special attention to curve berms and try to work down the high outside edges. True False
6. It is okay to groom against snowmobile traffic on the left side of the trail if that side is rougher than the right side of the trail. True False
7. The best temperature for grooming with a drag is between 5 and 25 degrees F (-15 and -4 degrees C). True False
8. The most effective grooming speed with a drag is:
 - a. 3 to 4 mph (5 to 6.5 kph)
 - b. 5 to 7 mph (8 to 11 kph)
 - c. 8 to 10 mph (13 to 16 kph)
 - d. 10 to 12 mph (16 to 19 kph)
9. Grooming at night will generally produce the best quality trail because temperatures are typically colder so the snow will flow better and set up harder; traffic volumes are also typically at their lowest which helps provide set up time. True False
10. Mirrors on a tractor are typically useless and aren't important since there isn't a need to see behind the tractor. True False
11. It is okay to dump snow from the groomer on roads and driveways because it helps warn motorists and landowners that they are crossing a snowmobile trail. True False

12. A tractor should descend steep hills in the same gear that is used to climb the hill.
True False
13. Normally, roads should never be groomed wider than twice the width of the grooming equipment.
True False
14. If the grooming tractor becomes stuck:
- a) quickly give it more throttle and spin the tracks
 - b) don't spin the tracks
 - c) gently rock the vehicle back and forth, packing the snow
 - d) consider unhooking the drag – sooner versus later
 - e) a shovel may be needed
 - f) all of the above except a
 - g) a, c, d, e, and f above
15. When backing up with a grooming drag on the trail, a pile of snow is often created. It is okay to leave this pile of snow on the trail since snowmobiles will knock it down.
True False
16. When grooming trails, always:
- a) stay on the trail with the grooming equipment
 - b) feel free to pick new routes to provide variety since the groomer will go through anything
 - c) turn around only where there is ample turning room and it is known that the snow base will support the equipment, preferably using areas where turn-a-rounds have been made before
 - d) a and c above
 - e) a, b, and c above
17. If there is a lack of new snow in the middle of the trail, the options could include:
- a) set the drag blades to pull snow in from the trail edges
 - b) use the front blade on the tractor to pull snow in from the right edge of the trail
 - c) don't bother grooming – put the wheels down until you find snow
 - d) operate the groomer on the outside edge of the trail
 - e) a, b and d above
 - f) b and d above
18. Never stop to remove rocks, logs, limbs or other debris that is lying on or in the trail surface because they provide a solid filler that helps the trail last longer.
True False
19. When snow is spilling out the side of a drag, it means that the drag is carrying too much snow, likely set too low, and is not working effectively. True False
20. A groomer operator should be cautious about following a snowmobile track across an open area.
True False

21. Common operator abuses of tracked equipment include:
- a) going too slow
 - b) spending too much time warming up the engine
 - c) performing unwarranted pre-operation inspections
 - d) unauthorized modifications
 - e) none of the above
 - f) a, b, c, and d above
22. Proper use of a tiller for snowmobile trail grooming requires:
- a) a tractor with sufficiently large horsepower
 - b) a good front blade operator
 - c) deep snow cover
 - d) none of the above
 - e) a, b, and c above
23. If groomer operators encounter poor visibility caused by high wind, heavy snowfall, fog, or a combination of these conditions when grooming, and it is difficult to see where to groom, they should:
- a) simply stop right where they are, leave all lights on with the engine idling
 - b) contact their grooming manager or a dispatcher to advise them of the situation and location
 - c) stay with the equipment and wait for visibility to improve
 - d) get out and walk
 - e) a, b, and c above
 - f) none of the above
24. It is never a good idea to get out of the tractor and walk back to check the trail, particularly when alone at night. True False
25. When using a tiller and parts of the trail do not look good, like they were not processed and finished okay, it may indicate:
- a) the tiller depth is set too high
 - b) engine speed on the tractor is too slow
 - c) the tiller isn't engaged in the float position
 - d) excessive groundspeed with the tractor
 - e) the front tractor blade wasn't used to cut moguls and create an even surface area on the trail, so the tiller is "open" over the moguls
 - f) all of the above
26. If the tractor is driven too fast while operating a tiller, the tracks will throw snow out to the side and also over the top of the tiller onto the snow surface which has already been prepared. True False

Chapter Five:

MAINTAINING GROOMING EQUIPMENT

Preventative Maintenance

The place for grooming equipment is out on the trails working – not sitting in a service shop waiting for parts or broken down out on the trail with a failed component that was not properly maintained. There are enough things that can go wrong through normal grooming operations without aggravating the problems with a lack of due care.

The key to ensuring that downtime and emergency repairs are kept to an absolute minimum, and that the equipment remains safe to operate, is establishing a comprehensive preventative maintenance program. As noted earlier, it is far easier to preserve what you have than to restore what you've lost.

Regardless of the type of maintenance being performed, there are four elements to the work that need to be addressed:

Four Elements to Preventative Maintenance

1. Inspection.

A great deal can be learned about the condition of a vehicle by carefully looking, listening, smelling, and feeling. While general overall surveillance is important, the areas where failures commonly occur should be identified and the inspection criteria and methods detailed. A good operator does not necessarily have to be a good mechanic. But a good operator does need to be observant and aware of their machine's sounds and appearances.

2. Lubrication.

Ensuring that lubricating fluids are fresh and full is extremely important for tracked vehicles. As well as lubricating, installing fresh lubricants will displace water, dirt, and spent lubricant which has accumulated in places it shouldn't be.

3. Adjustment.

Tracked vehicles have a number of adjustments that can compensate for wear and changes in alignment. Ensuring that mechanical adjustments are made to maintain specific characteristics is the best way to prevent nuisance failures in the field that can have serious consequences for the operator.

4. Repair.

Any part or system found to be damaged, worn out, or otherwise not doing its job must be promptly and fully repaired by a qualified individual.

Types of Maintenance

There are a number of types of maintenance performed at different times for different purposes. A good overall maintenance program should include the following:

- First-Time Operation of a New Unit Inspection
- Pre-Season Inspection and Maintenance
- Pre-Operation Inspection and Maintenance
- Post-Operation Inspection and Maintenance
- Routine Shop Inspection and Maintenance
- Off-Season Storage Procedures

Each type of maintenance has a different purpose, so procedures should be developed for each one based upon the type of equipment. And since there are such a wide variety of grooming tractors, drags, tillers, and attachments currently available, it is impossible to provide generic preventive maintenance procedures that fit all situations. Therefore, general guidelines as to what each type of maintenance procedure should address include:

First-Time Operation of a New Unit

It is important to both the condition of the vehicle and safety of the operator to proceed slowly when operating a new vehicle (or a “new used” vehicle) for the first time.

While the Owner’s Manual should have detailed procedures, the following basic procedures should be followed prior to operating any vehicle for the first time:

- Visual inspection of entire vehicle, inside and outside.
- Check fuel and oil levels and fill as necessary.
- Familiarization with all controls and functions including Owner’s Manual recommendations.
- With engine running, verify that all gauges are operating and within specified limits.
- Proceed very slowly, getting the feel of the vehicle and its characteristics.
- After the first 10 hours or as specified in the manual, check for loose bolts, nuts, fittings, etc.

Pre-Season Inspection and Maintenance

If the off-season recommendations below have been followed, readying the vehicle at the start of a new season should be relatively easy:

- Refer to maintenance records and be sure that all required work was performed.
- Check all fluid levels and look for signs of leaks.
- Install and/or adjust tracks.
- Inspect all welded joints and stress areas for cracks.
- Inspect bearings, joints, and all moving parts.

Pre-Grooming Operation Inspection and Maintenance

Before starting operations for a new day, the operator should be required to perform a pre-operation inspection. A set program should be developed for each piece of equipment based upon the manufacturer's recommendations. See the sample Daily Grooming Log in the Appendix for a sample Pre-Operation Checklist.

Post-Grooming Operation Inspection and Maintenance

As discussed earlier, many tracked vehicles should not be simply turned off at the end of a work session or engine damage can occur. Develop a routine for shutting down the vehicle at the end of the run, based upon the manufacturer's recommendations. This shut-down/cool-down period is also an excellent time to walk around the equipment to perform a visual inspection, as well as to refuel. Oftentimes, it is also a good idea to remove excess snow and ice that may have accumulated on the equipment during the grooming run. See the Daily Grooming Log in the Appendix for a sample Post-Operation Checklist.

Routine Shop Inspection and Maintenance

In addition to the ongoing operational maintenance described in the two previous sections, most tracked vehicles require regular and frequent shop inspection and maintenance. A regular program should be developed for each machine and operators should be instructed as to when shop maintenance is required. A maintenance log can make this easier to remember and track. See the sample Vehicle and Equipment Report, the Vehicle/Equipment Maintenance Records form and the Grooming Equipment Maintenance Requests form in the Appendix for checklists useful for tractors. Table 5.1 provides a sample checklist that can be used for grooming drag maintenance.

Grooming Drag – Example Service Item Description	Frequency
Walk Around Inspection	Daily
Remove and Inspect Shear Bolt	Daily
Inspect Hydraulic System for Leaks	Daily
Check Blade Spring Tension	Daily
Check Cutting Blade Condition	Daily
Clean Ice and Snow Buildup from Face of Blades and Packing Pan	Daily
Clean Snow from Rear of Packing Pan	Daily
Check Rear Wheel Tire Pressure (22psi)	Daily
Inspect Wear Strips Under Side Rails	Weekly
Check Rear Skegs	Weekly
Torque Blade Mounting Bolts (150 Ft. Lbs.)	Monthly
Torque Wheel Nuts (70 Ft. Lbs.)	Monthly
Grease Blade Pivot Points	Monthly
Remove, Clean, and Lube Draw Bar	Monthly
Check and Re-Pack Rear Wheel Bearings	Yearly
Touch Up Paint as Necessary	Yearly
Check Blade Height Adjustment (refer to Owner's Manual)	Yearly

Table 5.1 Sample Grooming Drag Maintenance Checklist

Off-Season Storage Procedures

Most tracked vehicles spend a significant part of the year sitting completely idle. Taking the time to properly store them simply makes sense in terms of protecting a major investment. While an off-season maintenance program unique to each vehicle should be developed based upon the manufacturer's recommendations, the following general guidelines should be followed universally:

- Clean and service the battery and battery compartment.
- Change the oil, transmission fluid, hydraulic fluids, and filters.
- Lube all fittings to displace water and spent grease.
- Check for wear points: track belts and related components, wheel wear, cracks in carrier and frame, hydraulic assemblies, etc.
- Check engine compartment for belt wear, tension, and alignment; throttle linkages and springs; broken or worn wiring; etc.
- Clean interior and exterior.
- Park in a garage if possible. If exposed to weather, remove or cover tracks to prevent Ultra Violet (UV) light damage to the rubber. If stored with tracks on, release tension.
- All engines (gas and diesel) should be started monthly and operated for at least 15 minutes to keep valve stems coated and to put moving parts in a different position.

General Tractor Maintenance Tips

- If at all possible, completely thaw out the grooming tractor for every scheduled maintenance session regardless of the mess and time involved. It's the only way to discover cracks in welds, missing small parts like nuts and screws, etc., and will save on valuable downtime later.
- Always jack up each track for journal bearing lubrication, for checking track tension, and for track adjustment. When greasing track journals, a very thorough greasing is required – it's easy to under grease but nearly impossible to over-grease them.
- Aluminum or steel track cleats are often over tightened when fastened to track belts, which can lead to premature belt failure. A torque wrench should always be used for this task since manufacturer guidelines typically stipulate tightening the nuts to as low as 25 foot-pounds (34 Newton-meters).
- Always refuel the grooming tractor at the end of a grooming run. This ensures the unit is ready to go the next time it is needed or in the event of an emergency. It also helps avoid condensation buildup in the empty fuel tank, which could lead to fuel line freeze up and/or engine problems.

CHAPTER QUIZ

1. Preventative maintenance can help prevent downtime and keep equipment safe to operate. The four main elements of a good preventative maintenance program include:
 - a) measurement, fueling, tinkering and replacement
 - b) monitoring, greasing, tuning and overhauls
 - c) inspection, lubrication, adjustment and repair
 - d) surveillance, servicing, alignment and rebuild
2. Before operating any grooming equipment, always check all fluid levels and check for leaks. True False
3. If you identify a repair that needs to be made while doing a pre-operation inspection, go ahead and do the scheduled grooming run and report the condition to the Grooming Manager when you return. True False
4. When operating a vehicle for the first time, run it as fast as it will go to see if it has enough power. True False
5. A tractor should be shut off as quickly as possible after a grooming shift to conserve fuel. True False
6. Never remove ice or snow that has built up on grooming equipment since it might damage the equipment; plus the added weight is good for trail compaction. True False
7. Grooming tractors should be stored inside or have their tracks removed during the off-season to avoid UV light damage to rubber tracks and belts. True False

Chapter Six:

RECORD KEEPING

The importance of keeping accurate and complete records of all aspects of a grooming program cannot be overemphasized. Good records are an important management tool, promote adherence to procedures, and may help limit liability should problems occur.

It is the responsibility of everyone to keep records. As pointed out in Chapter Five, a good preventive maintenance program is an important safety management tool, so keeping good records is a must. A cavalier attitude by any person toward not performing good recordkeeping that facilitates preventative maintenance should not be tolerated.

At the same time, if records are kept they should be used! Be sure that records are used to analyze the performance of the grooming program and as a yardstick to measure improvements. Don't just "file'em and forget'em."

Recommended Forms

All grooming programs are encouraged to develop forms to suit their particular needs. The following is a brief description of various forms that can be important to the management of a successful grooming program. Samples can be found in the Appendix.

Daily Groomer Operator's Log Form

It's important to the management of the grooming program that a running log is kept for each vehicle showing where and when it was used. Hour and odometer readings provide useful data and the remarks sections can be used to record any unusual events during the run for future reference. Some daily logs also incorporate a daily pre- and post-operation checklist, such as is shown on the sample Log in the Appendix. It is also recommended that a trail map, on which the trail segments groomed that day have been highlighted, is attached to the daily log to visually document what trails were groomed.

Grooming Equipment Maintenance Requests

The groomer operator has an important role in the overall preventive maintenance of the equipment. However, groomer operators may not be mechanics and need clear instructions as to what to check and how to tell if it's good or bad. Checklists such as the sample in the Appendix provide an easy format for operators to communicate the maintenance needs of the equipment to grooming managers and mechanics.

Vehicle/Equipment Reports and Maintenance Records

Every vehicle or piece of equipment should have its own log to track daily hours, miles/kilometers, fuel consumption, maintenance, and repairs. The examples in the Appendix can be combined on the front and back of one page to easily log monthly use and maintenance.

Corrective Action Form

Groomer operators are often the best “eyes and ears” for the trail system given the regularity and frequency that they travel the area’s trails. During grooming operations, operators may identify conditions on or directly adjacent to the trail that need correcting. A form like this provides a mechanism to report these situations, can document when they are corrected, and is important to overall trail safety and risk management.

CHAPTER QUIZ

1. Groomer operators’ only purpose is to groom trails and therefore should not concern themselves with watching for unsafe situations or missing signs along the trails or reporting these situations to the Grooming Manager.
True False
2. Record keeping is a nice thing to do and should be done only when an operator has time for it.
True False
3. It is important to track fuel, labor, maintenance, and other operating costs, along with the number of hours that are required to groom an area’s trails, to determine per hour or per mile/kilometer grooming costs. True False
4. A Daily Operator’s Log can:
 - a) be a waste of time
 - b) help document trails groomed, unusual events, and equipment use
 - c) increase liability
 - d) none of the above

Chapter Seven:

RECOMMENDATIONS for GROOMER OPERATOR CERTIFICATION

Purpose

It is recommended that groomer operators be certified to help ensure the proper operation and maintenance of snowmobile trail grooming equipment. Certification should consist of a combination of training and testing to help ensure equipment operators understand correct grooming principals, techniques, procedures and other pertinent subject matter. Certification can also help ensure that the expenditure of grooming funds results in smooth trails that are safe and hold up to snowmobile traffic as long as possible.

Who Should Be Certified?

While groomer operator certification requirements are ultimately a local decision by each state, province, territory, or subunits thereof, it is recommended that all groomer operators receive a minimum level of training and certification. In some areas, groomer operator certification may be mandatory in order for the grooming area to qualify for liability insurance. In all instances operator certification can serve as an excellent risk management tool, so it should be universally encouraged.

Since even experienced groomer operators can benefit from periodic training and refresher courses, it is recommended that, if an area adopts certification requirements, all operators receive the initial training as well as the initial certification, irrespective of their experience level or if they are an employee, volunteer, or contractor.

How Long Should A Certification Valid?

While the length of time a groomer operator certification is valid is a local decision, it is recommended that they be valid for no more than four years if the operator continues to operate the same type of equipment. If the grooming equipment is replaced with either newer models or a different type of tractor and/or implement, the operator's training and certification should be updated at that time to include training and certification for the new equipment.

Levels of Operator Certification

It is recommended that two levels be used for a Groomer Operator Certification Program:

- Level 1 – Trainee:** for those operators who have completed a minimum of four (4) hours of classroom training and successfully passed a written test.

Level 2 – Certified Groomer Operator: for those operators who have completed Level 1 requirements plus a minimum of 16 hours of supervised on-trail equipment checkout and operation.

It is recommended that a Level 1 Trainee Operator should not operate the grooming tractor without a Level 2 Operator or Grooming Manager/Instructor in the tractor with them. It is recommended that a Level 2 Operator be used to provide the minimum 16 hours of in-tractor equipment operation instruction to Level 1 Trainees.

Operator Certification Core Subjects

It is recommended that groomer operator certification relate to core subjects listed in Chapter One and covered by this Resource Guide, along with topics pertinent to local area conditions and procedures. The sample Groomer Operator Training Record checklist in the Appendix also provides a detailed list of potential training and certification topics. Additionally, the chapter quizzes in this Guide may be used by jurisdictions as a basis from which to develop local certification tests as applicable. Recommended core subjects for certification could include:

- **Introduction to Grooming:** glossary of terms; grooming objectives, principles and steps; basic snow physics; grooming manager and schedules; and the source of funding for the local grooming program.
- **Grooming Equipment Features:** general overview of tractors; tractor components and characteristics; front blades; general overview of implements; drag features; tillers; compactor bars; and snowmobiles as groomers.
- **Equipment Operation Guidelines:** operator safety; general operating guidelines; grooming basics; effective grooming tips for a drag; proper use of the front blade; tips for operating tracked vehicles; tips to avoid equipment damage; and Ten Common Operator Abuses.
- **Equipment Maintenance:** Four Elements of Preventative Maintenance; first time operation of new units; pre-season inspection and maintenance; pre- and post-operation/shift inspection; regularly scheduled maintenance; and off-season storage.
- **Record Keeping:** cover all logs and reports required by the local grooming program.
- **Local Issues:** local trail maps, trail routes, special closures or sensitive areas, local laws and regulations, emergency contacts and procedures.
- **Hands-On Equipment Operation and Check Out:** in-cab instruments and gauges, backing up the tractor, hooking implements to the tractor, starting and stopping, operating on the right side of the trail, side hill operation, front blade operation, implement operation, proper fueling procedures, pre- and post-operation visual inspections.

GLOSSARY OF TERMS

Compactor Bar: (Packer Bar)	A rear mounted bar with a plastic comb used to compress deep new snowfall (over 18 in. / 46 cm) prior to grooming the trail with a drag or for early season trail set-up.
Dead-Head Miles:	Return trip over the same trail because of a dead end trail.
Front Blade:	A front mounted blade used to doze snow drifts, to help pull new snow in from the sides of the trail, and to provide rear grooming implements a properly prepared surface to process the snow.
Groom:	To get into a state of readiness for a specific objective; to take care of the appearance of; to make neat and tidy = trail maintenance; the mechanical alteration of the snow to provide a safe, smooth surface for travel.
Groomed Miles:	Total miles put on the groomer during the process of grooming the entire trail system.
Groomer:	A grooming tractor equipped with grooming implements (drag, tiller, or compactor bar).
Groomer Operator:	An employee or volunteer that is in physical control of and operates the grooming tractor.
Grooming Drag: (Drag)	An implement pulled behind the grooming tractor which does the actual grooming of the snow on the trail bed. Also called a planer or surfacer by some manufacturers.
Grooming Manager:	A local official or club member charged with coordinating grooming activities, including establishing schedules and priorities. Some areas call this person the Trail Master or the Grooming Coordinator.
Grooming Speed:	The speed the groomer travels over the trail while performing the grooming operation (typically recommended to be 5 to 7 mph / 8 to 11 kph).
Grooming Tractor: (Tractor)	A heavy-duty, two or four-tracked vehicle for which the primary purpose is to provide the pulling power for grooming implements. Also called a Prime Mover.

Hours of Operation:	The time that the grooming tractor actually spends grooming the trails, not necessarily as recorded by the hour meter.
IASA:	The International Association of Snowmobile Administrators, which consists of state, provincial, territorial and federal government officials with responsibility for administering snowmobile trail, safety, and/or enforcement programs.
Miles of Trail:	One-way miles of trail in the system, including loops and dead-ends.
Moguls:	A pattern of mounds, dips, and ruts in a trail.
Operation Log:	Used to record the date, the hours of operation, miles of trail groomed as recorded by the vehicle odometer, time in and out, parts of the trail system groomed, and general comments regarding repairs and maintenance records.
Scarifier:	A blade used to scar icy surfaces to rough them up, usually mounted in the front row of multi-blade drags or on the bottom of the front tractor blade.
Snowmobile Trail:	A compacted snow road for use by snowmobiles and other authorized over-snow vehicles.
Tiller:	A hydraulically driven, rear mounted implement similar to a roto-tiller that mechanically processes and mixes snow.
Trail Bed:	The compacted snow surface or trail.
Trail Grooming:	The activity of producing a smooth, uniformly compacted snow surface with a uniform high density through the use of mechanical equipment.
Track Packing:	Using the tracks of the grooming tractor to pack the snow without the use of any grooming implements.

RESOURCES

A.F.M. Industrial – manufacturer of Trailmaker Drag and supplier of John Deere conversions and used equipment. Smith Falls, Ontario; toll free 800-325-7929 or 613-283-4001. www.afmi.ca

Aspen Equipment – new Bombardier groomers and used equipment. Upper Midwest USA: Bloomington, MN – 952-888-2525; Duluth, MN – 218-624-1111; Ankeny, IA – 515-965-1000; Omaha, NE – 402-894-9300. www.aspenequipment.com

ASV – manufacturer of Track Truck, DX, and Posi-Track vehicles. Grand Rapids, MN; toll free 800-346-5954 or 218-327-3434. www.asvi.com

Camoplast Industrial (formerly Bombardier Industrial) – manufacturer of Bombardier groomers. Headquarters – Granby, Quebec 450-776-3600; Northeast US and Canada – Granby, Quebec 612-759-0405; Western Canada – Calgary, Alberta 403-279-7271; Inter-Mountain US – Salt Lake City, UT 801-364-8266; Rocky Mountain US – Grand Junction, CO 970-242-7150; Far West US – Reno, NV 775-359-7517. www.industrial.camoplast.com

Charles Vogel Enterprises – manufacturer of Arrowhead Groomers and Ultra Arrow Track. St. Germain, WI; toll free 888-412-1722 or 715-479-4200. www.charlesvogelent.com/groomers

Cook's Equipment – Tucker Sno-Cat dealer, used equipment, and parts. Newport, VT; 802-334-7779. www.cooksequipment.com

Custom Snow Cat, Thiokol, DMC and LMC Parts – by machinist Pat Foster. Wallace, ID; 208-556-0153. <http://wallace-id.com/foster.html>

Ebert Welding – manufacturer of Sur-Trac Groomers. New Liskeard, Ontario; toll free 866-476-6899 or 705-647-6896. www.ebertwelding.com

Easy Pull Trail Groomer – pull behind snowmobile groomer. Two Harbors, MN; 218-834-2485. www.angelfire.com/biz/easypull/

Fall Line Corporation – aftermarket parts and drive sprocket recovering. Reno, NV; toll free 800-325-5463 or 775-827-6400. www.fallline.com

Hans-Hall – supplier for track belting, cleats, guides, and other parts. Murray, UT; 801-747-1110. www.hans-hall.com

HICO (Hydraulic Industries Corporation) – supplier of all types of snow groomer parts. Vaudreuil, Quebec; 450-424-5411. www.hico.ca

Institute for Snow Research – Michigan Technological University, Keweenaw Research Center; research on Snow Paver. Houghton, MI; 906-487-2750.
www.mtukrc.org

JACA – pull behind snowmobile grooming equipment. Jemseg, New Brunswick; 506-488-2075. www.jacatrax.com

LaCross Enterprises – manufacturer of LaCross Groomers and Front Blades. East Jordan, MI; 231-536-7142. www.lacrossgroomer.com

Lamtrac, Inc. – manufacturer of Lamtrac Groomers. Haut-Lameque, New Brunswick; toll free 888-526-8722 or 506-344-1130. www.lamtrac.com

Marcel Grooming Equipment – tractor conversion groomers and used equipment. New Liskeard, Ontario; 705-647-5444. www.marcelgrooming.com

Mattracks – rubber track conversion systems. Karlstad, MN; 218-436-7000.
www.mattracks.com

Maxey Manufacturing – manufacturer of Maxey drags. Fort Collins, CO; toll free 800-456-2939 or 970-482-1202. www.maxeymfg.com

Minnesota Outdoor Sports Specialties – used equipment. Brainerd, MN; 218-828-7876. www.mn-outdoors.com

Mohawk, Ltd. – dealer for Pisten Bully and used equipment. Chadwicks, NY; 315-737-5456. www.mohawk ltd.com

Mountain Grooming – manufacturer of Mtn. Snow Drag and dealer for Sur-Trac Groomers and used equipment. Waitsfield, VT; 802-496-3836.
<http://mountaingrooming.com>

Oak Creek Golf & Turf, Inc. – Pisten Bully dealer. Calgary, Alberta; toll free 888-773-7335 or 403-279-2907. www.oakcreekgolf.com

Okner's Supply Company, Inc. – replacement parts for snow groomers. Denver, CO; toll free 800-294-3579 or 303-294-9291. www.okners.com

Permagroomer Snowgrooming Products (Industrial Tires Limited) – custom urethane products for snow groomers. Mississauga, Ontario; toll free 800-668-4725 or 905-625-1600. www.industrialtires.com/products/permagroomer.html

Peterson Equipment – dealer for Pisten Bully and used equipment. Logan, UT – 435-752-5110 and Seattle, WA – 253-815-6899. www.petersonequipment.com

Pisten Bully / Kassbohrer All Terrain Vehicles – manufacturer of Pisten Bully grooming equipment. Offices: Grand Junction, CO 970-245-9331; Lewiston, ME – 207-777-7300; Burnsville, MN – 952-345-3330; Reno, NV – 775-857-5014.

www.katvpb.com

Ski Tech Products (Engineered Filtration, Inc.) – snow vehicle maintenance products supplier. Manchester, CT; 860-432-0248. www.skitech-products.com

Sno Boss Groomers (Olson Manufacturing, Inc.) – manufacturer of Sno Boss drags. St. Germain, WI; 715-479-3006.

Snow Country Groomers – dealer for Arrowhead drags, Arrow Trak, Marcel drags, tractor conversion kits, and used equipment. Lena, WI; 920-829-5196.

www.snowcountrygroomers.com

Snow Groomers.Net – manufacturer of Sno-Master pull behind snowmobile groomer. Harbor Springs, MI; toll free 800-430-7120 or 231-526-7120. www.snowgroomers.net

Snow Track, LLC – dealer for Sur-Trac grooming equipment. Wausau, WI; 715-675-7554. www.ebertwelding.com

Spooner Machine, Inc. – manufacturer of Spooner Drag. Spooner, WI; toll free 888-552-0835 or 715-635-3220. www.spoonermachine.com

Team Track – manufacturer of quad tractor conversion kits, front blades, and the Team Track Drag. Plessisville, Quebec; toll free 866-363-1688 or 819-362-2221.

www.go-track.com

The Resort Bone Yard – used grooming equipment. Chadwicks, NY; toll free 800-225-6642 ext. 265. www.resortboneyard.com

The Shop Industrial – manufacturer of Mogul Master drags and the TSI Compactor Bar; also dealer for Tucker Sno-Cat, Bombardier, Argo, and Centaur grooming equipment, as well as used equipment. Lively, Ontario; toll free 800-663-DRAG or 705-682-1522.

www.mogulmaster.ca

Track, Inc. – Tucker Sno-Cat dealer, used equipment, parts, and service. Bloomington, MN; 952-888-7372. www.trackinc.com

Tucker Sno-Cat Corporation – manufacturer of Tucker Sno-Cat groomers. Medford, OR; toll free 866-SNO-CAT1 or 541-779-3731. www.sno-cat.com

VMC Right Track, Inc. – manufacturer of VMC groomers. Lachine, Quebec; toll free 800-985-8665. www.vmcrighttrack.com

REFERENCES

Black Hills Snowmobile Program Operations Manual; South Dakota Department of Game, Fish & Parks – Division of Parks & Recreation. 2004.

California Snowmobile Trail Grooming; California Department of Parks and Recreation – Off-Highway Motor Vehicle Recreation Division. 1997.

California Trail Grooming Operator Certification and Training Handbook; California Dept. of Parks and Recreation – Off-Highway Motor Vehicle Rec. Division. Nov. 1999.

General Guidelines for Snowmobile Trails Grooming – Training Manual and Workbook; New York State Office of Parks, Recreation & Historic Preservation – Bureau of Marine & Recreational Vehicles. May 1999.

Groomer Operations Manual and Trail Signing Guide; Colorado State Parks and the Colorado Snowmobile Association. 2003.

Gullett, W. (Tony); Wyoming State Trails Program, personal communication – grooming equipment operation, practices, and tips. March 2005.

Lang, R.M.; The Physics of Snow and Snow Surface Preparation. May 2005.

Pisten Bully 100 Operating Manual; Kassbohrer All Terrain Vehicles. 2004.

Snowmobile Groomer Operator Awareness Program; New Hampshire Dept. of Resources and Economic Development, Div. of Parks and Recreation – Bureau of Trails. 2004.

Snowmobile Trail Development Manual – Chapter 6: Trail Grooming; Alberta Snowmobile Association. October 1999.

Snowmobile Trail Development Manual – Chapter 7: Trail Grooming; Ontario Federation of Snowmobile Clubs. 1996.

Snowmobile Trail Grooming Guidelines; New Hampshire Department of Resources and Economic Development, Division of Parks and Recreation – Bureau of Trails. November 2002.

Snowmobile Trail Grooming Handbook; Michigan Department of Natural Resources. September 2000.

The Shop Industrial – Mogul Master Multi-Blade Planer Operating Manual. 2001.

Wells, Chuck; Idaho Department of Parks and Recreation, personal communication – tillers. February 2005.

Wyoming Snowmobile Program Operating Manual; Wyoming Division of State Parks & Historic Sites – Trails Program. 2002.

Appendix:

SAMPLE FORMS

Several sample forms are provided in this Appendix to help grooming managers and operators with the important task of record keeping. Every form has a specific purpose, although not every example may be pertinent to every area. The samples should be used by grooming managers to build a form that best fits their area and needs. The following sample forms are included in this Appendix:

- Weekly Grooming Schedule
- Daily Grooming Log
- Vehicle/Equipment Report
- Monthly Maintenance Records (can be copied on back side of Vehicle Report)
- Grooming Equipment Maintenance Requests
- Corrective Action Request
- Groomer Operator Training Record

DAILY GROOMING LOG

Date _____ Area _____ Operator _____

Sequence of Trails Groomed _____

Tractor _____ Implements _____ Width _____

Operator's Time: In _____ Out _____ Total Operator Hours _____

Odometer Begin _____ Odometer End _____ Total Miles Groomed _____

Hour Meter Begin _____ Hour Meter End _____ Total Tractor Hours _____

Temperature Range _____ Inches of New Snow _____ Traffic _____

Weather (circle all that apply): Clear Cloudy Sunny Windy Snowing Raining Other: _____

Remarks: _____

Pre-Shift Check List (Warm Up tractor for a minimum of 10 minutes)

Fuel Tank Full _____ amt. added Belts Gauges Track Grousers
 Engine Oil _____ amt. added Lights Wipers Track Belts
 Hydraulic Oil _____ amt. added Battery Mirrors Track Tension
 Anti-Freeze _____ amt. added Beacon Radio/Phone Track Wheels
 Wiper Fluid _____ amt. added Tools Shovel Hydraulic Hoses
 Fire Extinguisher Ice Scraper Flashlight Implements Survival Gear

Checked Out By: _____

End of Shift / Shut-Down Checklist (Idle tractor for a minimum of 10 minutes)

Fill Fuel Tank _____ amt. added Water Separator Checked Shoveled Off
 Implements in Down Position Brake On Plugged In Key Off
 Radio/Phone Off Maintenance Needs Recorded Daily Log Completed

Average Gauge Readings During Run: Engine RPM _____ Engine Temperature _____

Oil Pressure _____ Hydraulic Temperature _____

Checked In By: _____

Special Notes, General Comments, Repair Work Needed, Explain Any Downtime, etc. in space below:

VEHICLE & EQUIPMENT REPORT

Report Month/Year _____ Vehicle/Equipment Description _____
 Make _____ Model _____ Year _____ Unit # _____

DATE	OPERATOR	GALLONS OF FUEL	BEGIN HOURS	END HOURS	DESCRIPTION OF ACTIVITIES
1					
2					
3					
4					
5					
6					
7					
8					
9					
10					
11					
12					
13					
14					
15					
16					
17					
18					
19					
20					
21					
22					
23					
24					
25					
26					
27					
28					
29					
30					
31					
Totals:	Gallons of Fuel:		Hours:		

VEHICLE/EQUIPMENT MONTHLY MAINTENANCE RECORDS – record dates, quantity, costs

Engine Oil: Change & Add						
ATF						
Grease & Lube						
Anti-Freeze						
Washer Fluid						
	Fluids – Total Cost \$:					
Oil Filter						
Transmission Filter						
Air Filter Cleaned						
Air Filter Replaced						
Fuel Filter						
	Filters – Total Cost \$:					
Axle						
Bearing/set						
Washers	Small		Large			
Bogie Wheel – small						
Bogie Wheel – large						
Ice Breaker Wheel						
Drive Sprocket						
Track Belt						
Track Cleat						
Tightner Bolt						
Track Bolts						
Connector Bolts						
Spring Bolt						
	Tracks – Total Cost \$:					
Tie Rod Ends						
Trunion						
Nylon Block	Small		Large			
Drive Shaft & U-Joints						
	Steering and Drive Train – Total Cost \$:					
Water Pump						
Thermostat						
Alternator						
	Engine Components – Total Cost \$:					
Lights	Flood		Spot			
Strobe Light						
Switch						
Wipers & Blades						
Transmission Heater						
Battery						
	Electrical – Total Cost \$:					
Hydraulic Pump						
Hoses & Fittings						
	Hydraulics – Total Cost \$:					
Major Service/Overhaul						Cost \$
Other						Cost \$
Labor						Cost \$
	Total Monthly Maintenance Cost:					

GROOMING EQUIPMENT MAINTENANCE REQUESTS

Equipment Name/#: _____ Date: _____ Requested By: _____

Hour Meter Reading at time of Request _____ Odometer Reading at time of Request _____

ITEM	OK	NO	COMMENTS	ITEM	OK	NO	COMMENTS
Fuel				Steering			
Motor Oil				Brakes			
Hydraulic Oil				Controls			
Transmission Fluid				Heater/AC			
Anti-Freeze				Mirrors			
Washer Fluid				Wipers			
Brake Fluid				Controls			
Hydraulics				Beacon			
Transmission				Backup Alarm			
Rear End				Windows			
Tracks/Tires				Engine Temperature			
Front Blade				Hydraulic Temperature			
Drive Belts				Transmission Temperature			
Alternator				Gauges			
Hoses				Radio/Phone			
Exhaust				Air Filter			
Leaks				Horn			
Loose Bolts				SMV Sign			
Loose Objects				Cab Interior			
Teeth/Edges				Remove Snow/Ice			
Linkage/Tie Rods				Shovel			
Hinge Pins				Fire Extinguisher			
Hitch				First Aid & Survival Kits			
Lights				Tools, Tow Ropes, Etc.			
Seat Belts				Other			

CORRECTIVE ACTION REQUEST

PART 1 – Condition Needing Attention:

Location:

Recommended Action:

Reported By: _____ Date: _____

PART 2 – Corrective Action Taken:

Verified By:

Date:

GROOMER OPERATOR TRAINING RECORD

Operator's Name _____ Date _____

Trainer _____ Equipment Certified _____

Signature of Operator – Acknowledgement of Training _____

Introduction to Grooming	√	Equipment Operation	√
Glossary of Terms		Operator Safety	
Grooming Objectives		General Operating Guidelines	
Grooming Principles		Grooming Basics	
Grooming Practices		Effective Grooming Tips / Drag	
Basic Snow Mechanics		Operating Tracked Vehicles Tips	
Grooming Manager		Tips to Avoid Equipment Damage	
Grooming Schedules		10 Common Operator Abuses	
Source of Funding		Front Blade Tips	
Grooming Equipment Features	√	Equipment Maintenance	√
General Overview of Tractors		4 Elements of Prevent. Maintenance	
Tractor Components		1 st Time Operation of New Unit	
Tractor Characteristics		Pre-Season Inspection & Maintenance	
Front Blades		Pre-Operation/Shift Inspection	
General Overview of Implements		Post-Operation/Shift Inspection	
Grooming Drag Features		Regularly Scheduled Maintenance	
Tillers		Off-Season Storage	
Compactor Bars			
Snowmobiles as Groomers			
		Record Keeping	√
		All Required Logs & Reports	
Local Issues	√	Vehicle Check-Out Run	√
Trails Routes & Maps		In-Cab Instruments & Gauges	
Signing Guidelines		Backing & Hooking Up Implement	
Special Closures or Sensitive Areas		Start and Stop	
Local Laws		Operation on Right Side of Trail	
Emergency Procedures		Front Blade Operation	
		Implement Operation	
		Fueling	
		Pre & Post Visual Inspection	